

OEM CATALOGUE

---



**EMPOWERING  
YOUR WORLD  
WITH PRECISION**





**EMPOWERING  
YOUR WORLD  
WITH PRECISION**

# TABLE OF CONTENTS

## Ablerex

About us	4
A complete range for every need	10

## Single-phase line-interactive UPS

For PCs, Wi-Fi routers, home and networking devices - Ideal for home, small businesses and SMEs	12
GR 650-2200 VA • GR S 600-2000 VA	13

## Single-phase online UPS

For workstations and telecommunications, networking and video surveillance equipment, server rooms - Ideal for SMEs and large businesses	18
AR PRO Tower • AR PRO RT 1000-3000 VA	20
AR SMART Tower	24
OD • OD H RT 1000-3000 VA	26
MSIII Tower • MSIII RT 1/1 6000-10000 VA	28
MSII Tower • MSIII RT 3/1 10000-20000 VA	32

## Three-phase UPS

For server room, data centres, industrial automation, electromedical equipment - Ideal for SMEs and large businesses	36
GLM	38
KR PLUS 10-40 kVA • KR PLUS XL 10-40 kVA	39
TS 10-80 kVA	43
TT 100-500 kVA • TT GT 100-800 kVA	47
MD 15-900 kVA	54

## Single- and three-phase CPSS

<b>For EN 50171 applications: fire protection, smoke detection, emergency lighting, security and alarm systems</b>	<b>58</b>
CPSS single-phase 4000-10000 VA	60
CPSS three-phase 10-40 kVA	60

## Power quality device

<b>For the medical, telecommunications, industrial, energy distribution, transport, finance, tertiary and broadcasting sectors</b>	<b>66</b>
ESP Wall mount active filters • ESP Modular active filters	68
STS Central static transfer systems for maximum availability in critical applications	72
ATS Automatic transfer systems	74
BMS Wireless battery analysis, monitoring and protection system	76

# ABOUT US

## Pleased to meet you

We are an ISO 9001 and 14001 certified multinational that designs and manufactures UPS and PQD (Uninterruptible Power Supply and Power Quality Device) for applications of all types and sizes.

In business since 1994 and with over 100 patents, we guarantee power continuity and quality to companies, IT or electromedical facilities, telecommunications, services in everyday locations and for everyday activities, and technology at home or in the workplace.



## Providing answers

Our 150 engineers and a team of 1000 sales, marketing, logistics and production operators deliver projects, products and multilingual technical assistance worldwide.

Product assistance, transport and delivery optimisation, personalised documents, technical support: our watchwords are continuity, quality, reliability and transparency.

## Count on us

Over thirty years of international relations and experience have taught us the importance of establishing transparent and direct relations, and of guaranteeing excellent products to meet the specific needs of every business, from large to small companies, from the office to home.

We are a flexible and reliable partner, to guarantee energy and continuity in any situation.



## Picking up on the signs

Providing high-quality solutions to major international UPS manufacturers for three decades has given us authority and credibility. We have therefore decided to identify ourselves with a brand to respond to the needs of an increasingly demanding user base, attentive to the most sophisticated technologies that require continuity.

The AblereX product line was created on the basis of our experience.



## Sharing the future

We track the market trends, technological innovations, and the impact of the Internet of Things on goods and production.

Investing constantly in research and development, innovation, smart facilities for conscious production, synergies with other manufacturers, new *training tools*, *services* and more is a sign of our commitment to tackling the challenges of Economy 4.0 and looking to the future to build it day after day with clients who select us to work alongside them.

## The best follow-up there is

We serve large companies, as well as small companies aiming to grow by investing in steps. We choose a streamlined, tailor-made approach to simplify as much as possible and provide more efficient assistance.

We select a limited number of partners to build a development and action plan together in order to fully satisfy end customers.

Guaranteeing flexibility, promptness, speed, efficiency.



# ABOUT US

Founded in 1994, Ablerex is a multinational company specialising in manufacturing power protection solutions. The company is ISO 9001 and 14001 certified, and designs and manufactures a wide range of UPS (uninterruptible power supply) and power quality devices to ensure power reliability, quality and continuity.

It is a reliable partner that has been in business for 25 years, chosen as an OEM by the most popular UPS brands. With 150 engineers in R&D and over 1000 employees, the company is committed to innovative solutions. Customisation from design to specific applications and attention to quality are in the company's DNA.





Its worldwide production and operation sites, its staff of over 150 engineers and 1000 employees, and its multilingual technical support means that AblereX can guarantee the best solutions to meet all market needs.

The company is focussed on research and development, and has more than 100 advanced patents as well as the most important safety certifications such as CE, LVD, EMC and RoHS.

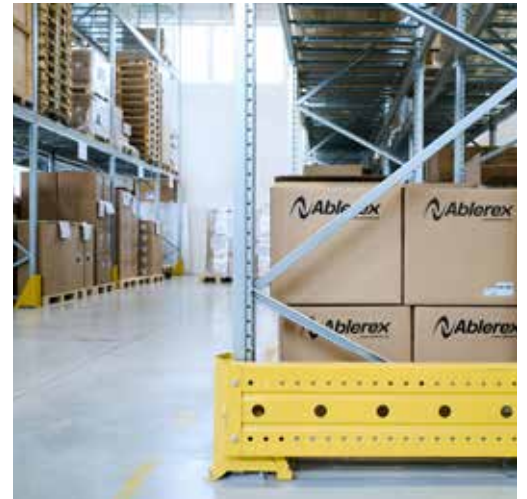
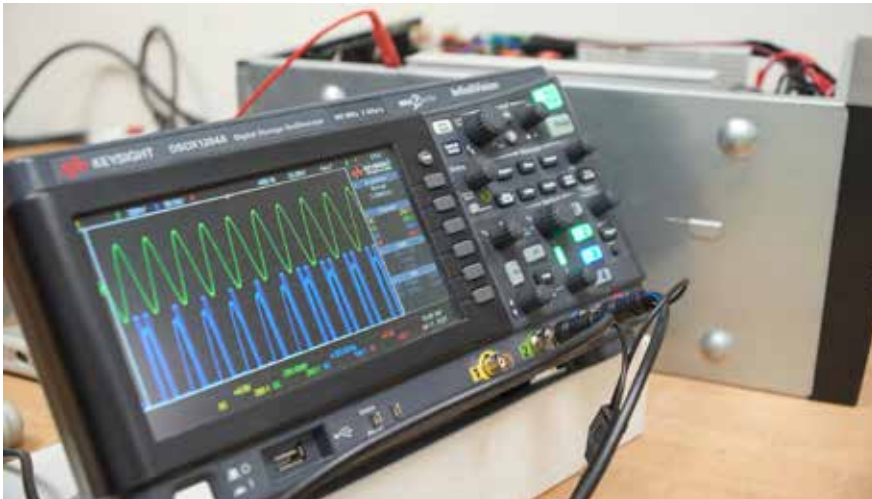

# ABOUT US

## In the right places

We have international production sites, EMEA headquarters in Milan, Italy - in an ideal time zone for communications, in a great location close to the international hub at Malpensa, - a warehouse near the port of Venice to optimise logistics and distribution times for faster deliveries throughout the country.

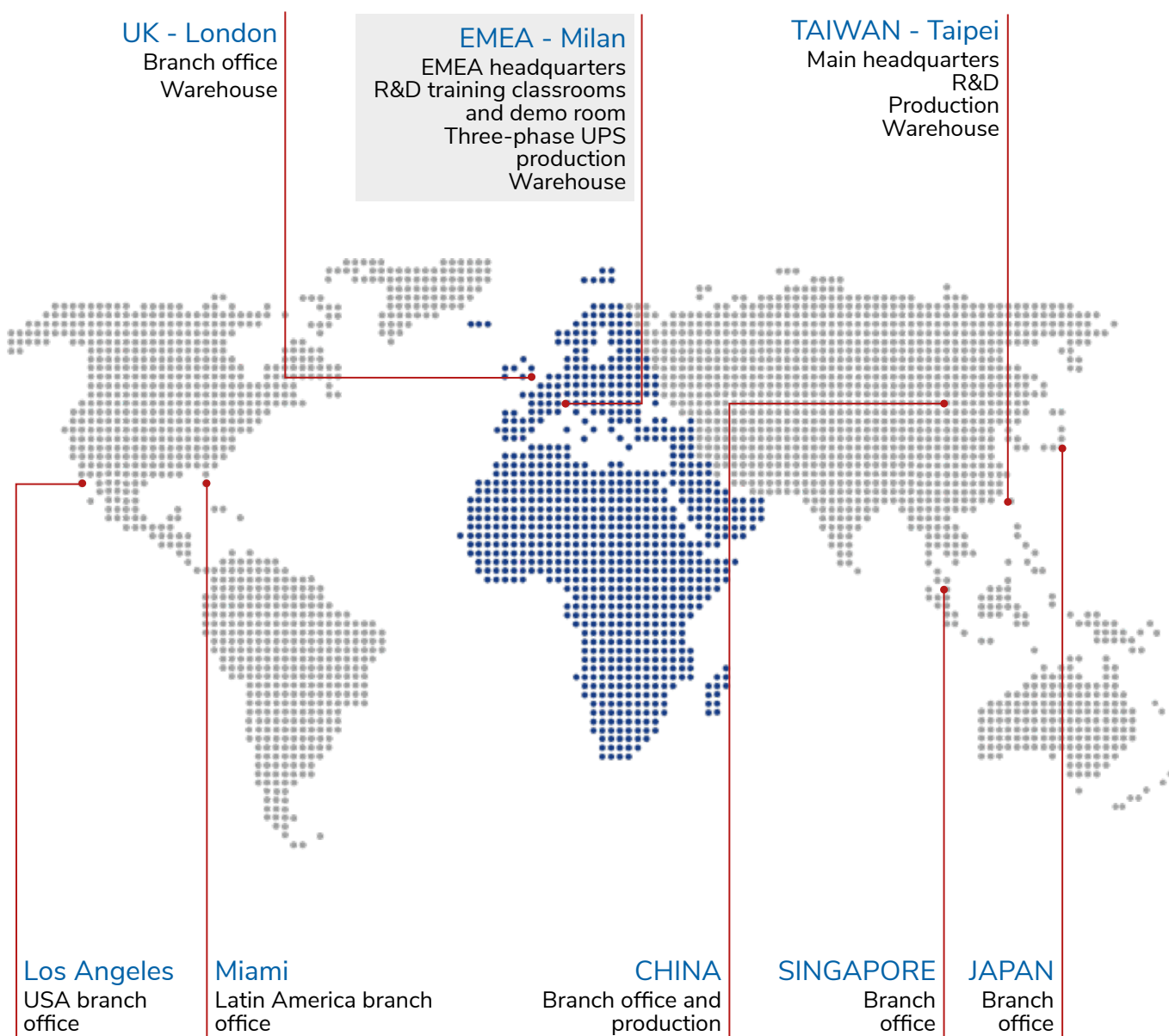

## Ten reasons to choose us



### From small to extra-large

specific solutions for applications of all types and sizes and for large and small companies.



### Prioritising excellence

constant investments in research, development and technologies to optimise production and create new product lines.



### More than one flagship

over 100 patents and safety certifications, and a full range of quality products.



### For all budgets, but not for everyone

advantageous prices, many previews and discounts on special orders, to access exclusive quality.



### Seniority in the field

three decades of business in the sector guarantee experience, reliability, support and efficient services.



### We get straight to the point

EMEA headquarters and warehouses in strategic areas to be in the right time zone for communications ensure faster and more efficient shipments and deliveries.



### Not only UPS for standard applications

we develop unique features for specific applications, and offer a range of products that can improve power quality to maximise efficiency and guarantee significant energy savings.

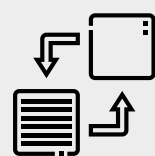

### Consider us your alter ego

Rapid and comprehensive product customisation, and technical and sales documentation; studies and implementation of customer projects.



### All for one, one for all

technical assistance, demo room, on-site training in Italy and remotely.



### Continuity with a capital C

we understand the importance of technology in all our daily lives, and we are committed to ensuring its continuity at all times.

# A COMPLETE RANGE FOR EVERY NEED

## LINE-INTERACTIVE UPS



**GR**  
650VA - 2200VA

**GR S**  
600VA - 2000VA

## SINGLE-PHASE UPS



**AR PRO Tower**  
1000VA - 3000VA

**AR PRO RT • OD PLUS**  
1000VA - 3000VA

**AR SMART Tower**  
1000VA - 3000VA

**OD H**  
1000VA - 3000VA



**MSIII Tower**  
6000VA - 10000VA



**MSIII RT 1/1**  
6000VA - 10000VA



**MSII RT 3/1**  
10000VA - 20000VA

## THREE-PHASE MODULAR UPS



**MD**  
UPS 60 kVA

**MD**  
UPS 120 kVA

**MD Combo**  
UPS 60 kVA

**MD**  
UPS 250 kVA

**MD**  
UPS 450 kVA

**MD**  
UPS 600 kVA

**MD**  
UPS 900 kVA

### THREE-PHASE ONLINE UPS



**KR Plus**  
10 kVA - 40 kVA

**KR Plus XL**  
10 kVA - 40 kVA

**TS**  
10 kVA - 80 kVA

**TT**  
100 kVA - 500 kVA

**TT GT**  
100 kVA - 800 kVA

### CPSS SINGLE-PHASE - THREE-PHASE



**CPSS 1/1**  
4000VA - 10000VA

**CPSS 3/3**  
10 KVA - 40 KVA

### POWER QUALITY DEVICES



**ESP**  
Active filters

**STS**

**ATS**  
Active transfer switches

**BMS**  
Battery monitoring system

## SINGLE-PHASE LINE-INTERACTIVE UPS



Plug and play line-interactive UPS to protect home and small business devices



**GR**  
650-2200 VA



**GR S**  
600-2000 VA

# SINGLE-PHASE LINE-INTERACTIVE UPS

## GR - GR S

- Line-interactive UPS to protect devices in the home, micro business and SMEs.
- Connected devices are always available because they can be powered up when there is no mains power.
- Automatic restart after prolonged blackouts means that it is always ready to protect your loads.
- The built-in automatic voltage regulator (AVR) stabilises the power when there are mains faults (e.g. spikes, sags, over- and under-voltages etc.), providing high levels of power protection and quality.
- Supplied with PowerMaster, intuitive software that can be downloaded for free. All you need in a box: supplied with input, output power cables and USB cable to protect hardware and data.
- The backlit LCD display makes it easy to read the UPS status, so all parameters can be kept under control.
- Easy battery replacement.
- The plug-in feature ensures that the battery is always charged: the UPS charges the battery even when it is switched off.
- The built-in USB communication port makes it easy to connect to the PC.
- All needed cables included: input, output power and USB cables.

### Low cost of ownership due to longer expected battery life

- Wide input allowable tolerance in both voltage and frequency (160-290V - 45-65 Hz): prevents batteries from going into operation when there is a major variation in input power.
- ABDM (Automatic Battery Discharge Management) protects batteries from deep discharge by increasing the cut-off voltage (battery cut voltage), the voltage at which a battery is considered fully discharged.
- Charge control: prevents overcharging of batteries that leads to their degradation by modulating the voltage to the battery to maintain a full charge during its operation.
- Automatic testing every 24 hours allows early detection of problems protecting batteries from failure.

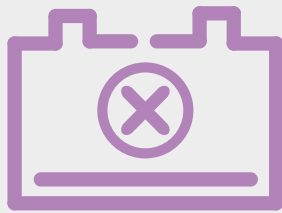

### PowerMaster: UPS monitoring and management software

Main features of the monitoring and control software (available free of charge at [www.ablerex.eu/download](http://www.ablerex.eu/download)):

- quick and easy installation and configuration via USB;
- orderly, automatic closure of the applications and operating system, even if the user is not there;
- UPS monitoring and power supply event reporting;
- transmission of alarms for the most common power supply problems and notification of system shutdown via email and text message;
- automatic testing of UPS and battery;
- available for Windows, MAC, Linux, etc. (full list available at [www.ablerex.eu/download](http://www.ablerex.eu/download)).



## GR 650-2200 VA

Plug&play UPS for the protection of home and small business devices



## GR S 600-2000 VA

Pure sine wave UPS for the non-stop supply of high end devices or with PFC power supply.  
UPS equipped with phone and data lines protection



### Applications

- PCs
- Wi-Fi routers
- Video game consoles
- TVs
- Satellite receivers
- POS
- Cash registers
- Surveillance cameras
- Home monitoring devices

### Applications

- Workstations
- Gaming PCs
- Small servers
- Networking equipment
- Hi-Fi and home theatre TV
- Video game consoles
- Satellite receivers
- Video surveillance
- Pellet stoves

### Uptime table

Consulting the summary table below will let you quickly identify a model based on the total VA/W consumption of the devices to be protected.

Model	GLAMOR - Line-interactive					GLAMOR S - Line-interactive				
	650 VA	1000 VA	1200 VA	1600 VA	2200 VA	600 VA	800 VA	1000 VA	1500 VA	2000 VA
UPS power in W	360	500	600	900	1200	420	560	700	1050	1400
Battery	1 of 12V		2 of 12V			1 of 12V		2 of 12V		
Device input power in Watts	Uptime in minutes	Uptime in minutes	Uptime in minutes	Uptime in minutes	Uptime in minutes	Uptime in minutes	Uptime in minutes	Uptime in minutes	Uptime in minutes	Uptime in minutes
52.5	29	42	70	72	>90	30	42	72	>90	>90
105	5	17	30	31	42	13	17	30	43	43
210	4	4	12	12	16	4	6	13	17	17

Indicative input power of various devices (you are advised to check actual input power)

- WI-Fi router 20/30 W • POS + Cash register 40/50 W • NAS 30/60 W • 43" TV 100 W • Inkjet printer / Scanner 180 W • Desktop PC + 21" LCD monitor 250 W • Desktop Gaming PC + 24" LCD monitor 500 W • High-end dual-processor PC + 32" LCD monitor 800 W • Rack/tower server from 300 to 1000 W • Video game console 140 W

# SINGLE-PHASE LINE-INTERACTIVE UPS

## GR - GR S

### GR TECHNICAL DATA SHEET

MODEL		GR650 LED	GR1000 LED	GR1200 LCD	GR1600 LCD	GR2200 LCD
POWER	VA	650	1000	1200	1600	2200
	W	360	500	600	900	1200
INPUT	Rated voltage	160 – 290 Vac				
	Frequency	45 – 65 Hz				
OUTPUT	Rated voltage	220/230/240 Vac ± 10%				
	Frequency on battery power	50/60 Hz ±1 Hz				
	Waveform	Pseudo-sine wave				
	Output sockets	1 IEC 320-C13 + 1 Schuko		3 IEC 320-C13 + 2 Schuko		
GENERAL	Dimensions (WxDxH) mm	100x292x140		148x315x198		
	Weight (kg)	5	5.5	9	10.5	11.8
	Alarms	Audible and visual alarm alerts for: power failure, low battery, overload, and UPS fault				
	Protection	Overload, short circuit, deep discharge, overcharging				
	Plug-in battery charging feature	Standard for all models				
	Cold start from the battery without mains power	Standard for all models				
BATTERY	Number and battery type		12V VRLA, AGM (maintenance-free lead)			
			1 of 12V		2 of 12V	
	Uptime with internal battery (in minutes)*	50% load	4	4	12	9
75% load		1	1	6	5	4
ENVIRONMENTAL PARAMETERS	Operating temperature**	0 – 40°C				
	Relative humidity	0% – 90% (without condensing)				
	Altitude (a.s.l.)	<1000 m with no power derating, >1000 m with 1% derating for every 100 m.				
	Audible noise at 1 m.	≤40 dB				
CONNECTIVITY	Communication ports	USB				
	User interface	LCD display showing: Operating mode (AC Mode/AVR Mode/Battery Mode), battery charge level, input and output voltage, percentage load, fault, or near end of battery life				
	Compatible software platforms	Microsoft Windows, Linux, Mac				
REGULATIONS	Standards	IEC EN 62040-1, IEC EN 62040-2, IEC EN 62040-3				
	Marking	CE, UKCA				

\* Subject to conditions \*\* To be verified according to the battery parameters

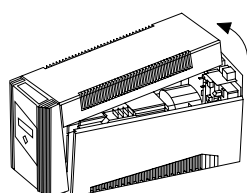

GR 650/1000

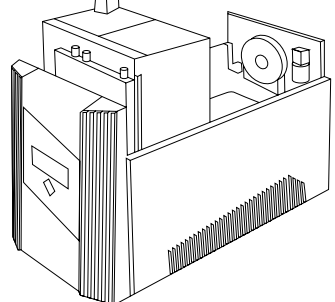
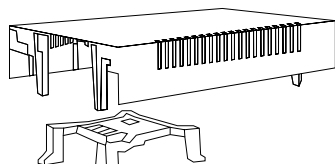

GR 1200/1600/2200

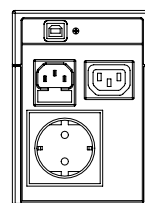

GR 650/1000

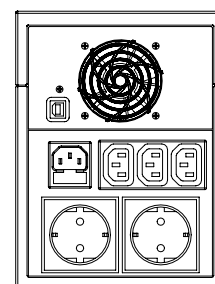

GR 1200/1600/2200

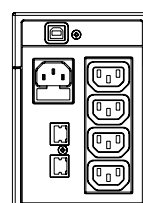

GR 650/1000 IEC

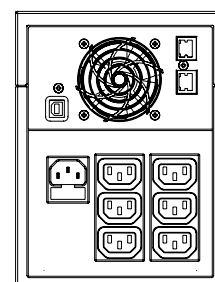

GR 1200/1600/2200 IEC

## GR S TECHNICAL DATA SHEET

MODEL		GR 600S	GR 800S	GR 1000S	GR 1500S	GR 2000S
POWER	VA	600	800	1000	1500	2000
	W	420	560	700	1050	1400
INPUT	Rated voltage	160 – 290 Vac				
	Frequency	45 – 65 Hz				
OUTPUT	Rated voltage	220/230/240 Vac ± 10%				
	Frequency on battery power	50/60 Hz ± 1 Hz				
	Waveform	Sine wave				
	Output sockets	1 IEC 320-C13 + 1 Schuko		3 IEC 320-C13 + 2 Schuko		
GENERAL	Dimensions (WxDxH) mm	116x305x171		165x393x198		
	Weight (kg)	5.5	7.1	9.3	12.4	12.6
	Alarms	Audible and visual alarm alerts for: power failure, low battery, overload, and UPS fault.				
	Protection	Overload, short circuit, deep discharge, overcharging				
	Plug-in battery charging feature	Standard for all models				
	Cold start from the battery without mains power	Standard for all models				
BATTERY	Number and battery type		12V VRLA, AGM (maintenance-free lead)			
			1 of 12V		2 of 12V	
	Uptime with internal battery (in minutes)*	50% load	7	4	5	4
internal		2	2	3	2	1
ENVIRONMENTAL PARAMETERS	Operating temperature**	0 – 40°C				
	Relative humidity	0% – 90% (without condensing)				
	Altitude (a.s.l.)	<1000 m with no power derating, >1000 m with 1% derating for every 100 m.				
	Audible noise at 1 m.	≤40 dB				
CONNECTIVITY	Communication ports	USB				
	User interface	LCD display showing: Operating mode (AC Mode/AVR Mode/Battery Mode), battery charge level, input and output voltage, percentage load, fault, or near end of battery life				
	Compatible software platforms	Microsoft Windows, Linux, Mac OS				
REGULATIONS	Standards	IEC EN 62040-1, IEC EN 62040-2, IEC EN 62040-3				
	Marking	CE, UKCA				

\* Subject to conditions \*\* To be verified according to the battery parameters

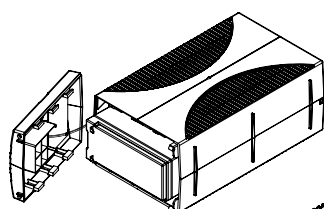

GR 600 - 800 S

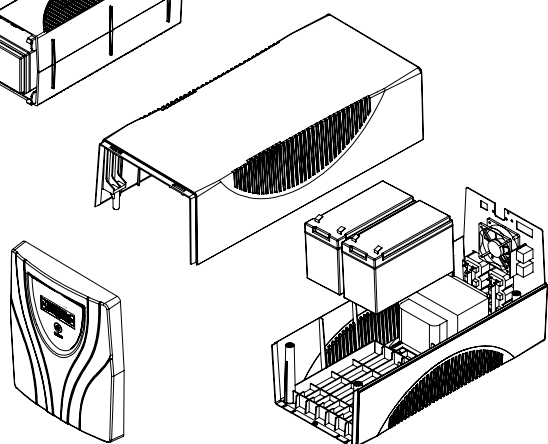

GR 1000 - 2000 S

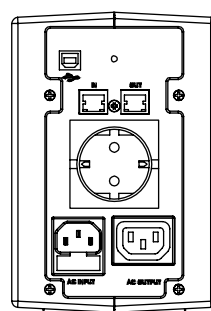

GR 600 - 800 S

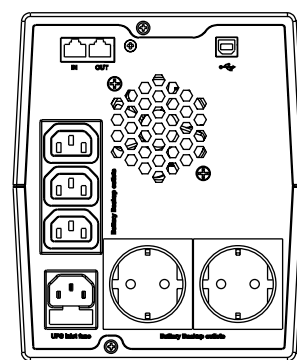

GR 1000 - 2000 S

# SINGLE-PHASE ONLINE UPS

Online UPS for maximum protection and longer uptime of critical devices for small, medium and large businesses



**AR PRO Tower**  
1000VA - 3000VA

**AR PRO RT**  
1000VA - 3000VA

**AR SMART Tower**  
1000VA - 3000VA



**OD PLUS • OD H**  
1000VA - 3000VA



**MSIII Tower**  
6000VA - 10000VA



**MSIII RT 1/1**  
6000VA - 10000VA



**MSII RT 3/1**  
10000VA - 20000VA

## AR PRO Tower - AR PRO RT

- Online Double-Conversion technology (VFI) from 1000VA to 3000VA with a power factor 1.
- Lithium battery ready.
- Flexible design offering both rack or tower installation with rotating display panel to suit.
- Easy installation.
- Low running costs with selectable high-efficiency (VFI) and ECO modes.
- Extended autonomies for maximum availability via external battery banks.
- User-friendly downloadable monitoring software supporting the main OS providing monitoring functions, diagnostics and automatic controlled shutdown of connected loads.
- Constant voltage constant frequency (CVCF) output mode offering maximum protection to sensitive loads.
- High overload capacity.
- Wide input voltage and frequency ranges reducing battery switching resulting in maximum service life.
- Configurable battery reserve percentage from 3% to 100% of available capacity.
- Real-time battery autonomy remaining available through the display.
- Two sets of IEC sockets that can be programmed separately.
- Cold start.
- Firmware can be upgraded easily to implement new features.
- EPO or On/Off with remote option.
- RS232, USB and mini slot to accept optional communication cards.
- Supplied with input and output power cables

### Key options

- Communication cards to include RS-485 Modbus, SNMP/web and relay interface with programmable dry contacts to integrate with various systems, such as BMS, PLC, SCADA and AS400.
- External manual bypass panels with additional sockets.
- External battery cabinets.
- Lithium battery upgrade.
- 8A super charger.
- Smart Ambient Temperature Detector
- Temperature compensation.

### Longer battery life

- Set the battery discharge level (3-100%) with the free software.

### Battery reserve management

- The UPS turns off when it reaches the set residual battery charge level.
- The UPS can be switched on again manually even without mains power.

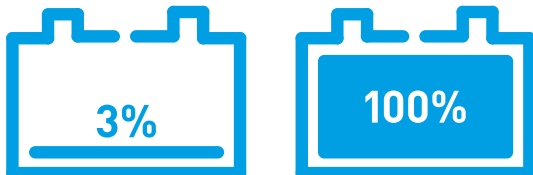

Indicative input power of various devices  
(you are advised to check actual input power)

- Router 30 W • POS + Cash register 50 W • NAS 60 W • 43" TV 100 W • Inkjet printer / Scanner 180 W • Desktop PC + 21" LCD monitor 250 W • Desktop Gaming PC + 24" LCD monitor 500 W • High-end dual-processor PC + 32" LCD monitor 800 W • Rack/tower server from 300 to 1000 W • Video game console 140 W

### Uptime table

Consulting the summary table below will let you quickly identify a model based on the total VA/W consumption of the devices to be protected.

ARES Online			
Model	1000 VA	2000 VA	3000 VA
UPS power in W	900	1800	2700
Device input power in Watts	Uptime in minutes	Uptime in minutes	Uptime in minutes
52,5	> 90	> 90	> 90
105	60	90	> 90
210	33	72	> 90
315	20	50	65
455	14	33	42
595	9	21	31
700	7	18	26
900	5	15	18
1050		12	15
1225		9	13
1400		7	12
1800		5	8
2100			6
2700			4

ARES and ODIN are the ideal UPS for applications that require extended battery operation and for medium-voltage substations in accordance with CEI 0-16.

Their advanced technology maximises battery life and ensures high efficiency.

## AR PRO Tower 1000-3000 VA

For applications that require tower models.



## AR PRO RT 1000-3000 VA

Suitable for all rack types including compact. RT models with lockable sockets are extremely versatile: the rotating display panel means they can be easily transformed into tower versions.



### Applications

- High-end PCs
- Workstations and servers
- Server rooms and micro data centres
- Electromedical equipment
- Network and telecommunications equipment
- Medium-voltage substations
- PLC control cabinets
- BMS and SCADA systems
- Video surveillance, security and IoT devices

### Special applications

#### Medium-voltage substations and control cabinets (PLC)

Ablerex has a solution whenever you need residual battery capacity. With Ablerex firmware, you can be sure that the UPS always has enough battery capacity to be turned on again and power the load.

#### Benefits

- Built-in feature that is free and easy to implement.
- Backup of at least 60 minutes, residual charge control in accordance with CEI 0-16.
- Easily customisable residual battery capacity.
- Cold UPS start-up.
- Battery alarm and residual backup time indicator.
- Maximises battery protection and life.

#### To ensure in any conditions 24/7 opening of electric shutters or doors of shops, bars, restaurants, warehouses and service businesses

If an electric shutter is protected by a UPS, and for some reason the mains circuit breaker trips or there is no power, the open/close mechanisms cannot be operated. The “remote on/off” option means that the Ablerex UPS can be switched on even without mains power so the electric shutter can be opened or closed.

#### Benefits

- Option that is easy to implement on request.
- Reduces TCO by avoiding the need to overdimension the UPS and batteries to overcome long periods without power (e.g. when closing a business for holidays).
- Maximises battery protection and life.

## AR PRO Tower - AR PRO RT

### AR PRO TOWER TECHNICAL DATA SHEET

MODEL		AR1000 PLUS	AR2000 PLUS	AR3000 PLUS	
POWER	VA	1000	2000	2000	
	W	1000	2000	2000	
INPUT	Rated voltage*	110 – 300 Vac			
	Frequency	44 – 70 Hz			
	Power factor	>0.99			
OUTPUT	Rated voltage	200/208/220/230/240 Vac			
	Voltage distortion	<2% with linear load I, <3.5% with distorting load			
	Voltage stability	±1%			
	Frequency	50/60 Hz (selectable)			
	Frequency stability	±1 Hz or ±3 Hz (selectable)			
	Power factor	1			
	Crest factor	3:1			
	Waveform	Pure sine wave			
	Output sockets	3 x IEC C13 1 Schuko	3 x IEC C13 1 Schuko	3 x IEC C13 1 x IEC C19 2 Schuko	
EFFICIENCY	VFI mode	Up to 93%			
	ECO mode	Up to 98%			
GENERAL	Dimensions (WxDxH) mm	154x445x258.2	192x620x319.9	192x620x319.9	
	Weight (kg)	14.7	24.1	26.3	
	Alarms	Audible and visual alarm alerts for: power failure, low battery, bypass transfer, and UPS fault			
	Protection	Overload, overheating, short circuit, deep discharge, battery overcharging.			
	Operating mode	Multi-mode: VFI, ECO, Constant voltage constant frequency (CVCF) output.			
	Cold start from the battery without mains power	Included			
BATTERY	Battery type	12V VRLA, AGM (maintenance-free lead)			
	Number per string	3	6		
	Uptime with internal battery in minutes	50% load	14	15	12
		100% load	5	5	4
	Charging time (90%)	4 – 6 hours			
Battery expansion module dimensions (WxDxH) mm **	154x403.6x258.2	192x552.8x319.9			
ENVIRONMENTAL PARAMETERS	Operating temperature***	0 – 40°C			
	Relative humidity	0% – 90% (without condensing)			
	Altitude (a.s.l.)	<1000 m with no power derating, >1000 m with 1% derating for every 100 m.			
	Audible noise at 1 m.	≤50 dBA			
CONNECTIVITY	Built-in communication ports	USB, RS232, EPO and additional slots for optional cards			
	User interface	LCD and function keys (parameters: voltage, frequency, percentage load, battery voltage, output voltage, estimated uptime, UPS temperature).			
	Optional accessories	Cards: SNMP, RS485 ModBus and dry relay contacts			
	Compatible software platforms	Microsoft Windows, Linux, Mac OS, VMware			
REGULATIONS	Standards	IEC EN 62040-1, IEC EN 62040-2, IEC EN 62040-3			
	Marking	CE, UKCA			

\* Depending on the load \*\* Battery weight and configuration depends on the required uptime \*\*\* To be verified according to the battery parameters

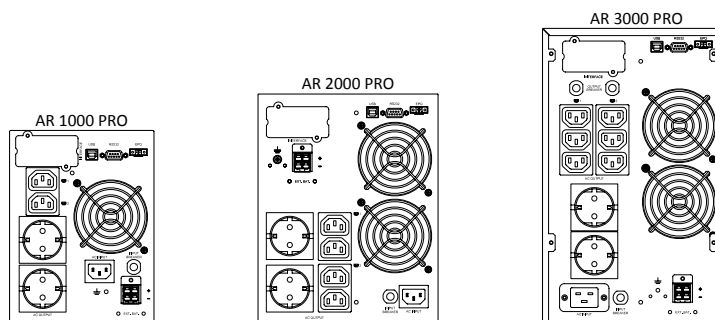



## AR RT PRO TECHNICAL DATA SHEET

MODEL		AR1000 PRO RT	AR2000 PRO RT	AR3000 PRO RT	
POWER	VA	1000	2000	3000	
	W	1000	2000	3000	
INPUT	Rated voltage*	110 – 300 Vac			
	Frequency	44 – 66 Hz			
	Power factor	>0.99			
OUTPUT	Rated voltage	200/208/220/230/240 Vac			
	Voltage distortion	<3% with linear load, <7% with distorting load			
	Voltage stability	±1%			
	Frequency	50/60 Hz (selectable)			
	Frequency stability	±1 Hz or ±3 Hz (selectable)			
	Power factor	1.0			
	Crest factor	3:1			
	Waveform	Pure sine wave			
	Output sockets	3 x IEC C13	6 x IEC C13	6 x IEC C13 1 x IEC C19	
EFFICIENCY	VFI mode	Up to 93%			
	ECO mode	Up to 98%			
GENERAL	Dimensions (WxDxH) mm	440x454x88 (2U)	440x640x88 (2U)	440x640x88 (2U)	
	Weight (kg)	15.8	24.4	27	
	Alarms	Alarms Audible and visual alarm alerts for: power failure, low battery, bypass transfer, and UPS fault.			
	Protection	Overload, overheating, short circuit, deep discharge, battery overcharging.			
	Operating mode	Multi-mode: VFI, ECO, Constant voltage constant frequency (CVCF) output.			
	Cold start from the battery without mains power	Included			
BATTERY	Battery type	12V VRLA, AGM (maintenance-free lead)			
	Number per string	3	6		
	Uptime with internal battery in minutes	50% load	10	11	9
		100% load	2.5	2.5	1.5
	Charging time (90%)	5 hours			
Battery expansion module dimensions (WxDxH) mm **	440x454x88(2U)	440x640x88 (2U)			
ENVIRONMENTAL PARAMETERS	Operating temperature***	0 – 40°C			
	Relative humidity	0% – 95% (without condensing)			
	Altitude (a.s.l.)	<1000 m with no power derating, >1000 m with 1% derating for every 100 m.			
	Audible noise at 1 m.	≤50 dBA			
CONNECTIVITY	Built-in communication ports	USB, RS232, EPO and additional slots for optional cards			
	User interface	LED, LCD and function keys (parameters: voltage, frequency, load percentage, battery voltage, output voltage, estimated uptime, UPS temperature).			
	Optional accessories	Cards: SNMP, RS485 ModBus, and dry contact relays			
	Compatible software platforms	Microsoft Windows, Linux, Mac OS, VMware			
REGULATIONS	Standards	IEC EN 62040-1, IEC EN 62040-2, IEC EN 62040-3			
	Marking	CE, UKCA			

\* Depending on the load \*\* Battery weight and configuration depends on the required uptime \*\*\* To be verified according to the battery parameters

AR1000 RT PRO

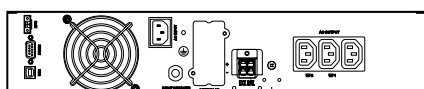

AR2000 RT PRO

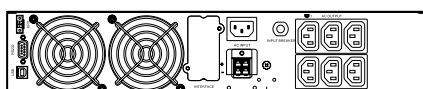

AR3000 RT PRO

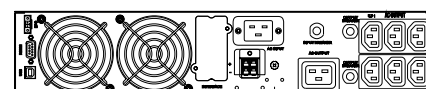

# AR SMART Tower

- Online Double-Conversion technology (VFI) from 1000VA to 3000VA with a power factor 0.9.
- Easy installation.
- Low running costs with selectable high-efficiency (VFI) and ECO modes.
- User-friendly downloadable monitoring software supporting the main OS providing monitoring functions, diagnostics and automatic controlled shutdown of connected loads.
- High overload capacity.
- Constant voltage constant frequency (CVCF) output mode offering maximum protection to sensitive loads.
- Wide input voltage and frequency ranges reducing battery switching resulting in maximum service life.
- Configurable battery reserve percentage from 3% to 100% of available capacity.
- Cold start.
- Firmware can be upgraded easily to implement new features.
- EPO or On/Off with remote option.
- RS232, USB and mini slot to accept optional communication cards.
- Supplied with input and output power cables

### Key options

- Communication cards to include RS-485 Modbus, SNMP/web and relay interface with programmable dry contacts to integrate with various systems, such as BMS, PLC, SCADA and AS400.
- External manual bypass panels with additional sockets.

## AR SMART Tower 1000-3000 VA

The AR SMART Tower offering premium quality in its simplest format and perfect for POS, small network applications and IT equipment. With its advanced technology, battery life expectancy is maximised whilst delivering exceptional system efficiency and performance.



### Applications

- High-end PCs
- Workstations and servers
- Server rooms and micro data centres
- Electromedical equipment
- Network and telecommunications equipment
- Medium-voltage substations
- PLC control cabinets
- BMS and SCADA systems
- Video surveillance, security and IoT devices

## AR SMART TOWER TECHNICAL DATA SHEET

MODEL		AR1000 S	AR2000 S	AR3000 S	
POWER	VA	1000	2000	3000	
	W	900	1800	2700	
INPUT	Rated voltage*	110 – 300 Vac			
	Frequency	44 – 66 Hz			
	Power factor	≥0.98			
OUTPUT	Rated voltage	200/208/220/230/240 Vac			
	Voltage distortion	≤3% with linear load I, ≤4% with distorting load			
	Voltage stability	±1%			
	Frequency	50/60 Hz (selectable)			
	Frequency stability	±1 Hz or ±3 Hz (selectable)			
	Power factor	0.9			
	Crest factor	3:1			
	Waveform	Pure sine wave			
	Output sockets	3 x IEC C13 1 Schuko	3 x IEC C13 1 Schuko	3 x IEC C13 2 Schuko	
EFFICIENCY	VFI mode	>89%	>90%	>91%	
	ECO mode	>96%			
GENERAL	Dimensions (WxDxH) mm	147x308x224	192x425.8x249.9		
	Weight (kg)	11.7	23.9	32.9	
	Alarms	Audible and visual alarm alerts for: power failure, low battery, bypass transfer, and UPS fault			
	Protection	Overload, overheating, short circuit, deep discharge, battery overcharging			
	Operating mode	Multi-mode: VFI, ECO, Constant voltage constant frequency (CVCF) output.			
	Cold start from the battery without mains power	Included			
BATTERY	Battery type	12V VRLA, AGM (maintenance-free lead)			
	Number per string	2	4	6	
	Uptime with internal battery in minutes	50% load	5	5	6
		75% load	3	3	3
	Charging time (90%)	6 – 8 hours			
ENVIRONMENTAL PARAMETERS	Operating temperature**	0 – 40°C			
	Relative humidity	0% – 90% (without condensing)			
	Altitude (a.s.l.)	<1000 m with no power derating, >1000 m with 1% derating for every 100 m.			
	Audible noise at 1 m.	≤45 dBA	≤50 dBA		
CONNECTIVITY	Built-in communication ports	USB, RS232, EPO and additional slots for optional cards			
	User interface	LCD and function keys (parameters: voltage, frequency, load percentage, battery voltage, output voltage, UPS temperature).			
	Optional accessories	Cards: SNMP, RS485 ModBus, and dry contact relays			
	Compatible software platforms	Microsoft Windows, Linux, Mac OS, VMware			
REGULATIONS	Standards	IEC EN 62040-1, IEC EN 62040-2, IEC EN 62040-3			
	Marking	CE, UKCA			

\* Depending on the load \*\* To be verified according to the battery parameters

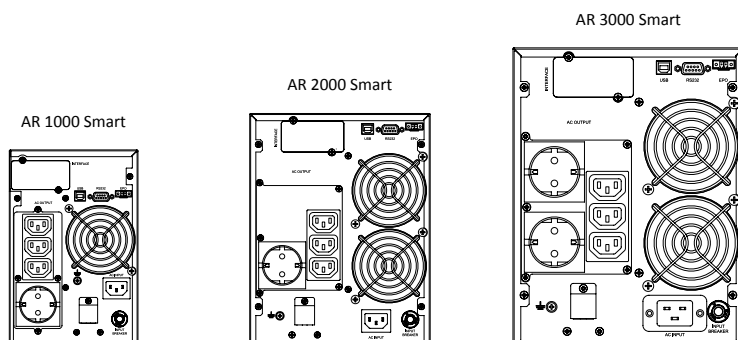

# SINGLE-PHASE ONLINE UPS

## OD PLUS - OD H

- Online double conversion technology (VFI) from 1000 VA to 3000 VA with a power factor of 0.9.
- Versatile: the display panel can be turned to transform the rack into a tower.
- Easy to install.
- Low running costs: the high efficiency VFI and ECO features minimise energy consumption.
- High uptime expandability.
- User-friendly monitoring software can be downloaded free and is compatible with the principle operating systems, for: monitoring functions, diagnostics, controlled shutdown of loads in the event of blackouts.
- High overload handling capacity.
- Constant voltage constant frequency (CVCF) output mode for maximum protection of particularly sensitive loads.
- Wide input voltage and frequency ranges reduce battery switching, thereby increasing battery life and

efficiency.

- Option to set the percentage residual battery charge from 3% to 100% of the available capacity.
- The accurately calculated residual operating time is shown on the display.
- Two sets of IEC sockets that can be programmed separately.
- Cold start option without mains power.
- The firmware can be upgraded easily to implement new features.
- EPO or On/Off, with remote option.
- RS232 and USB ports, slots for optional communication cards.

### Specifically for OD H

- Built to guarantee efficiency and performance from -10°C to 55°C.
- Batteries designed for extreme temperatures.

## OD PLUS - OD H 1000-3000 VA

When you need to prevent a service outage and ensure safety and continuity in extreme conditions, you need a robust, highly reliable UPS.



### Applications

- All applications in harsh climate areas
- Industrial applications
- IT and telecoms (transmitting-and-receiving stations)
- Underground transport
- Traffic control
- Wind farms
- Electromedical equipment

### Suitable for 600mm cabinets.

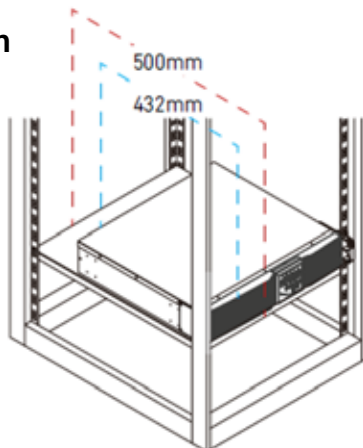

ODIN HARSH SINGLE-PHASE 1000-3000VA

## OD PLUS - OD H TECHNICAL DATA SHEET

MODEL		OD1000 Plus	OD2000 Plus	OD3000 Plus	
POWER	VA	1000	2000	3000	
	W	900	1800	2700	
INPUT	Rated voltage*	Standard	110/150/180-300 VAC (@-10°C~40°C Based on load percentage 0 ~ 60% / 0 ~ 75% / 0 ~ 100%)		
		Harsh	110/150/180-300 VAC (@-10°C~40°C Based on load percentage 0 ~ 60% / 0 ~ 75% / 0 ~ 100%) (@40°C~55°C 180-300 VAC Based on load percentage 0-60%)		
	Frequency	44 – 66 Hz			
	Power factor	>0.99			
OUTPUT	Rated voltage	Standard	200/208/220/230/240 Vac		
		Harsh	230 V, adjustable to 200/208/220/230/240(@-10°C~40°C) 230 V, adjustable to 220/230/240(@40°C~55°C)		
	Voltage distortion	<3% with linear load, <6% with distorting load			
	Voltage stability	±1%			
	Frequency	50/60 Hz (selectable)			
	Frequency stability	±1 Hz or ±3 Hz (selectable)			
	Power factor	Standard	0.9		
		Harsh	-10 /+ 40 °C PF = 0.9 , +40/+55 °C PF = 0.6		
	Crest factor	3:1			
	Waveform	Pure sine wave			
	Output sockets	3 x IEC C13	6 x IEC C13	6 x IEC C13 1 x IEC C19 lockable**	
	EFFICIENCY	VFI mode	up to 92%		
		ECO mode	up to 97%		
	GENERAL	Dimensions (WxDxH) mm	440x405x88 (2U)	440x432x132 (3U)	440x432x176 (4U)
Weight (kg) ***		11.7	23	25	
Alarms		Audible and visual alarm alerts for: power failure, low battery, bypass transfer, and UPS fault.			
Protection		Overload, overheating, short circuit, deep discharge, battery overcharging.			
Operating mode		Multi-mode: VFI, ECO, Constant voltage constant frequency (CVCF) output.			
Cold start from the battery without mains power		Included			
BATTERY	Battery type	Sealed maintenance free lead acid 12Vdc			
	Number per string	3	6		
	Uptime with internal battery in minutes	50% Load	14	15	12
		100% Load	5	5	4
	Charging time (90%)	4 – 6 hours			
Battery expansion module dimensions (WxDxH) mm	440x430x88(2U)	440x430x176 (4U)			
ENVIRONMENTAL PARAMETERS	Operating temperature	0 – 40°C			
	Relative humidity	0% – 90% (non-condensing)			
	Altitude (a.s.l.)	<1000 m with no power derating, >1000 m with 1% derating for every 100 m.			
	Audible noise at 1 m.	≤50dB			
CONNECTIVITY	Built-in communication ports	USB, RS232, EPO and additional slots for optional cards			
	User interface	LED, LCD and function keys (parameters: voltage, frequency, percentage load, battery voltage, output voltage, estimated uptime, UPS temperature).			
	Optional accessories	Cards: SNMP, RS485 ModBus and dry relay contacts			
	Compatible software platforms	Microsoft Windows, Linux, Mac OS, VMware			
REGULATIONS	Standards	IEC EN 62040-1, IEC EN 62040-2, IEC EN 62040-3			
	Marking	CE			

\* Battery weight and configuration depends on the required uptime \*\* OD3000 Plus has 1 x IEC C19 lockable, while OD3000 HARSH does not have  
 \*\*\* To be verified according to the battery parameters

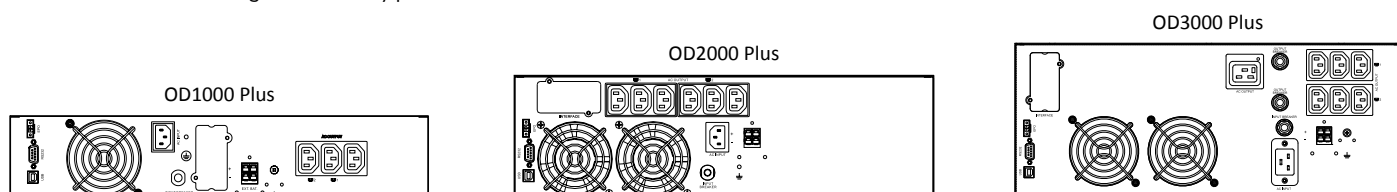

# MSIII Tower - MSIII RT 1/1

- Maximum power availability: kVA=kW.
- Up to 4 units in parallel, 3 + 1 redundancy possible with parallel kit.
- Low running costs: the high efficiency VFI and ECO features minimise energy consumption.
- User-friendly monitoring software can be downloaded free and is compatible with the principle operating systems, for: monitoring functions, diagnostics, controlled shutdown of loads in the event of faults.
- Cold start option without mains power.
- Wide input voltage and frequency ranges reduce battery switching, thereby increasing battery life and efficiency.
- Flexible battery configuration to suit your uptime requirements.
- Accurate calculated remaining uptime is shown on the display.
- Hot-swappable batteries: the batteries can be replaced while the UPS is running.
- Firmware can be upgraded easily to implement new features.
- EPO or On/Off, with remote option.
- 6-step operation test that can be activated manually.
- RS232 and USB ports, slots for optional communication cards.

### Key options

- Cards: RS485, RS232, SNMP/web and relay card with dry contacts to send the UPS status to various systems, such as BMS, PLC, SCADA and AS400.
- Parallel kit.
- External battery cabinets.
- External manual bypass with additional sockets.
- Rack mounting rail kit for RT models.

### Longer battery life

- Set the battery discharge level (3-100%) with the free software.

### Battery reserve management

- The UPS turns off when it reaches the set residual battery charge level.
- The UPS can be switched on again manually even without mains power.

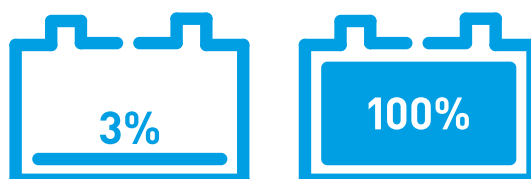

The MARS 6000–10000 VA UPS offers the maximum available power (kVA=kW), and can be connected in parallel for power or redundancy and are suitable for applications that require greater uptime.

## MSIII Tower 6000-10000 VA

## MSIII RT 1/1 6000-10000 VA



### Applications

- Critical IT applications
- Server rooms and micro data centres
- Network, VOIP and telecommunications equipment
- Video surveillance, security and IoT devices
- Electromedical equipment
- Industrial applications

### Parallel operation

Purchasing the parallel kit enables this feature, allowing the load to be shared by more than one UPS.

- Up to 4 units can be connected in parallel for a total power of 40 kVA.
- Load always protected thanks to the option of 3+1 redundancy (up to 30 kVA); in the event of a faulty UPS, it is replaced by the fourth module.
- No single point of failure thanks to the communication bus loop connection.

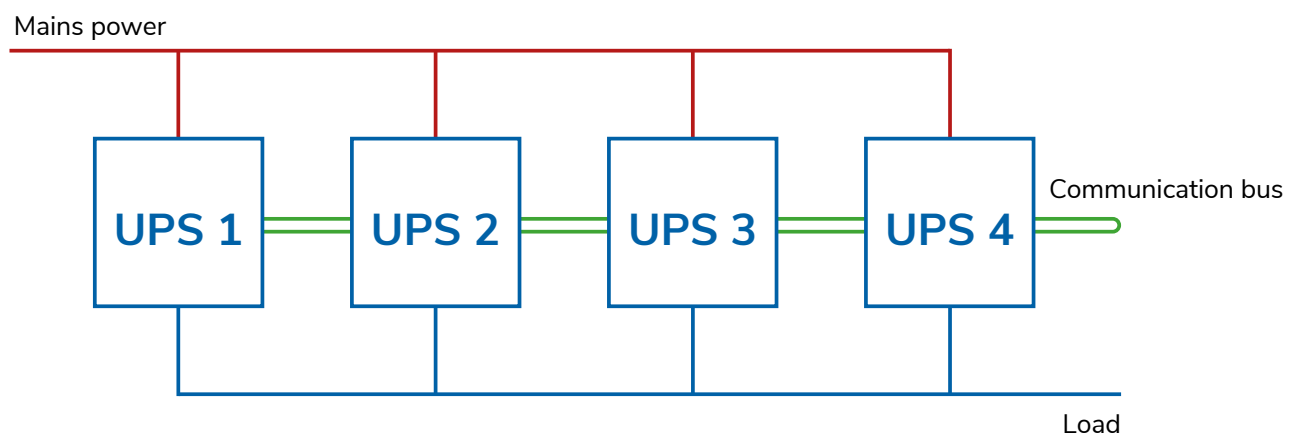

## MSIII Tower - MSIII RT 1/1

### MSIII TOWER TECHNICAL DATA SHEET

MODEL		MSIII 6000	MSIII 10000	
POWER	VA	6000	10000	
	W	6000	10000	
INPUT	Rated voltage*	110 – 280 Vac		
	Frequency	45 – 70 Hz		
	Power factor	>0.99		
OUTPUT	Rated voltage	200/208/220/230/240 Vac selectable		
	Voltage distortion	≤2% with linear load, ≤7% with distorting load		
	Voltage stability	±1%		
	Frequency	50/60 Hz (selectable)		
	Frequency stability	≤0.2% (free running)		
	Power factor	1		
	Crest factor	3:1		
	Waveform	Pure sine wave		
	Output connection	Terminal blocks		
EFFICIENCY	VFI mode	Up to 94%		
	ECO mode	Up to 98%		
GENERAL	Dimensions (WxDxH) mm	240x700x513	288x700x513	
	Weight (kg)	59	78	
	Alarms	Audible and visual alarm alerts for: power failure, low battery, bypass transfer, and UPS fault.		
	Protection	Overload, overheating, short circuit, deep discharge, battery overcharging.		
	Operating mode	Multi-mode: VFI, ECO, frequency converter (CVCF)		
	Cold start from the battery without mains power	Included		
	Parallel connection	Up to 4 units for 3+1 redundancy		
BATTERY	Battery type	12V VRLA, AGM (maintenance-free lead)		
	Uptime with internal battery in minutes	50% load	12	11
		100% load	4	4
	Charging time (90%)	4 – 6 hours		
Battery expansion module dimensions (WxDxH) mm **	288x663x661			
ENVIRONMENTAL PARAMETERS	Operating temperature***	0 – 40°C		
	Relative humidity	0% – 90% (without condensing)		
	Altitude (a.s.l.)	<1000 m with no power derating, >1000 m with 1% derating for every 100 m.		
	Audible noise at 1 m.	≤60 dBA		
CONNECTIVITY	Built-in communication ports	USB, RS232, EPO, remote On/Off contact, and additional slots for optional cards		
	User interface	LCD and function keys (parameters: voltage, frequency, percentage load, battery voltage, output voltage, estimated uptime, UPS temperature).		
	Optional accessories	Cards: SNMP, RS485 ModBus, dry relay contacts		
	Compatible software platforms	Microsoft Windows, Linux, Mac OS, VMware		
REGULATIONS	Standards	IEC EN 62040-1, IEC EN 62040-2, IEC EN 62040-3		
	Marking	CE, UKCA		

\* Depending on the load \*\* Battery weight and configuration depends on the required uptime \*\*\* To be verified according to the battery parameters

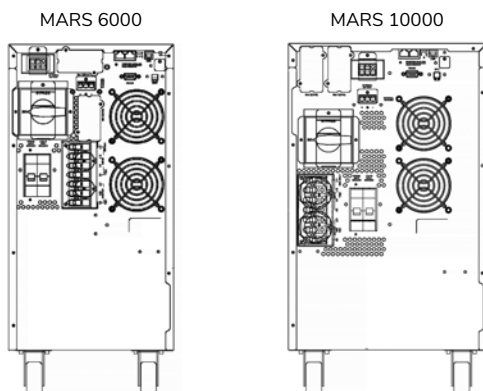



## MSIII RT 1/1 TECHNICAL DATA SHEET

MODEL		MSIII 6000 RT	MSIII 6000 RT C	MSIII 10000 RT	
POWER	VA	6000	6000	10000	
	W	6000	6000	10000	
INPUT	Rated voltage*	110 – 280 Vac			
	Rated frequency	45 – 70 Hz			
	Power factor	>0.99			
OUTPUT	Rated voltage	200/208/220/230/240 Vac selectable			
	Voltage distortion	≤2% with linear load, ≤7% with distorting load			
	Voltage stability	±1%			
	Frequency	50/60 Hz (selectable)			
	Frequency stability	≤0.2% (free running)			
	Power factor	1			
	Crest factor	3:1			
	Waveform	Pure sine wave			
EFFICIENCY	VFI mode	Up to 94%			
	ECO mode	Up to 98%			
GENERAL	Dimensions (WxDxH) mm	440x680x88	440x680x176	440x680x132	
	Weight (kg)	18.5	60	21.5	
	Alarms	Audible and visual alarm alerts for: power failure, low battery, bypass transfer, and UPS fault.			
	Protection	Overload, overheating, short circuit, deep discharge, battery overcharging.			
	Operating mode	Multi-mode: VFI, ECO, frequency converter (CVCF)			
	Cold start from the battery without mains power	Included			
	Parallel connection	Up to 4 units for 3+1 redundancy			
BATTERY	Battery type	12V VRLA, AGM (maintenance-free lead)			
	Uptime with battery in minutes	50% load	Depends on the external battery cabinets	7	Depends on the external battery cabinets
		100% load	Depends on the external battery cabinets	3	Depends on the external battery cabinets
	Charging time (90%)	4 hours			
	Battery expansion module dimensions (WxDxH) mm**	440x685x132 (3U)	440x685x88 (2U)	440x685x132 (3U)	
ENVIRONMENTAL PARAMETERS	Operating temperature***	0 – 40°C			
	Relative humidity	0% – 90% (without condensing)			
	Altitude (a.s.l.)	<1000 m with no power derating, >1000 m with 1% derating for every 100 m.			
	Audible noise at 1 m.	≤60 dBA			
CONNECTIVITY	Built-in communication ports	USB, EPO, remote On/Off contact, and additional slots for optional cards			
	User interface	LCD and function keys (parameters: voltage, frequency, percentage load, battery voltage, output voltage, estimated uptime, UPS temperature)			
	Optional accessories	Cards: SNMP, RS232, RS485 ModBus, dry relay contacts			
	Compatible software platforms	Microsoft Windows, Linux, Mac OS, VMware			
REGULATIONS	Standards	IEC EN 62040-1, IEC EN 62040-2, IEC EN 62040-3			
	Marking	CE, UKCA			

\* Depending on the load    \*\* Battery weight and configuration depends on the required uptime    \*\*\* To be verified according to the battery parameters

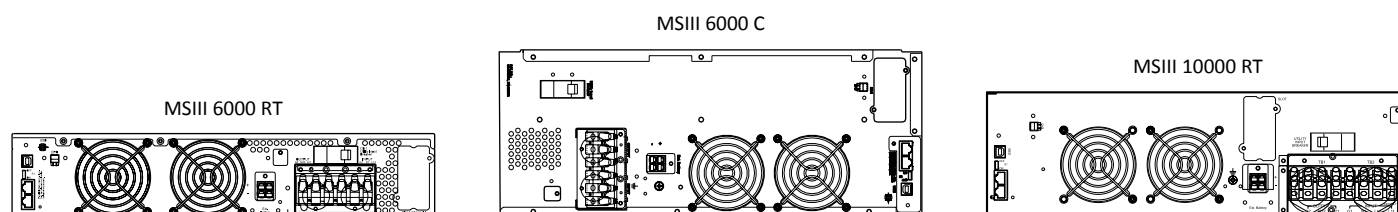

# SINGLE-PHASE ONLINE UPS

## MSII RT 3/1

- Online double conversion technology (VFI) from 10000 VA to 20000 VA with a power factor of 0.9.
- Versatile because the display panel can be turned to transform the rack into a tower.
- Full power bypass line with single-phase output.
- Up to 4 units in parallel, 3 + 1 redundancy possible with parallel kit.
- Low running costs: the high efficiency VFI and ECO features minimise energy consumption.
- User-friendly monitoring software can be downloaded free and is compatible with the main operating systems, for: monitoring functions, diagnostics, controlled shutdown of loads in the event of faults.
- Cold start.
- Wide input voltage and frequency ranges reduce battery switching, thereby increasing battery life and efficiency.
- Flexible battery configuration to suit your uptime requirements.
- 6-step operation test that can be activated manually.
- Dual input (for Mars II 20 kVA version only).
- RS232 port, slots for optional communication cards and remote EPO.

### Key options

- Cards: USB, RS-485 ModBus, SNMP/web and relay card with dry contacts to send the UPS status to various systems, such as BMS, PLC, SCADA and AS400.
- Isolation transformer.
- Parallel kit.
- Rail kit for rack mounting.
- External battery cabinets.
- External manual bypass with additional sockets.

## MSII RT 3/1 10000 - 20000 VA

Because of its convertible design, the MSII RT 3/1 combines reliability with great installation flexibility



### Applications

- Critical IT applications
- Server rooms and micro data centres
- Network, VOIP and telecommunications equipment
- Video surveillance, security and IoT devices
- Electromedical equipment
- Industrial applications

### Parallel operation

Purchasing the parallel kit enables this feature, allowing the load to be shared by more than one UPS.

- Up to 4 units can be connected in parallel for a total power of 40 kVA.
- Load always protected thanks to the option of 3+1 redundancy (up to 30 kVA); in the event of a faulty UPS, it is replaced by the fourth module.
- No single point of failure thanks to the communication bus loop connection.

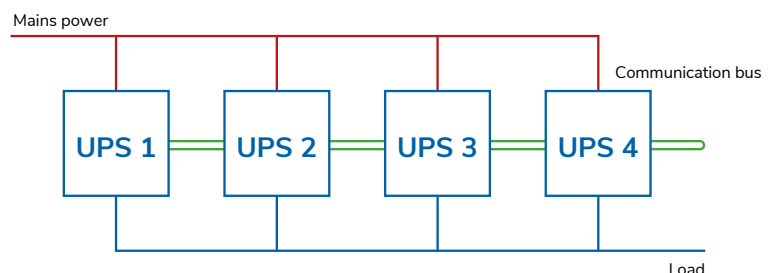

## MSII RT 3/1 TECHNICAL DATA SHEET

MODEL		MSII 10000 RT 3/1	MSII 15000 RT 3/1	MSII 20000 RT 3/1
POWER	VA	10000	15000	20000
	W	9000	13500	18000
INPUT	Rated voltage*	277 - 485 Vac	190 - 485 Vac	
	Rated frequency	45 - 65 Hz	45 - 70 Hz	
	Power factor	>0.99		
OUTPUT	Rated voltage	200/208/220/230/240 Vac selectable		
	Voltage distortion	<3% with linear load, <7% with distorting load		
	Voltage stability	±1%		
	Frequency	50/60 Hz (selectable)		
	Frequency stability	≤0.2% (free running)		
	Power factor	0.9		
	Crest factor	3:1		
	Waveform	Pure sine wave		
	Output connection	Terminal blocks		
EFFICIENCY	VFI mode	Up to 93%		
	ECO mode	Up to 95%		
GENERAL	Dimensions (WxDxH) mm	440x680x132 (3U)	440x720x220 (5U)	
	Weight (kg)	28	36	
	Alarms	Audible and visual alarm alerts for: power failure, low battery, bypass transfer, and UPS fault.		
	Protection	Overload, overheating, short circuit, deep discharge, battery overcharging.		
	Operating mode	Multi-mode: VFI, ECO, frequency converter (CVCF)		
	Cold start from the battery without mains power	Included		
	Parallel connection	Up to 4 units for 3+1 redundancy		
BATTERY	Battery type	12V VRLA, AGM (maintenance-free lead)		
	Number per string	20		
	Uptime with battery (in min).	50% load	Depends on the external battery cabinets	
		100% load	Depends on the external battery cabinets	
	Charging time (90%)	6 hours		
Battery expansion module dimensions (WxDxH) **	440x680x132 (3U)	440x680x132 (5U)		
ENVIRONMENTAL PARAMETERS	Operating temperature***	0 - 40°C		
	Relative humidity	95% (non-condensing)		
	Altitude (a.s.l.)	<1000 m with no power derating, >1000 m with 1% derating for every 100 m.		
	Audible noise at 1 m.	≤50 dBA	≤60 dBA	
CONNECTIVITY	Built-in communication ports	RS232, EPO, additional slots for optional cards		
	User interface	LCD and function keys (parameters: voltage, frequency, load percentage, battery voltage, output voltage, UPS temperature).		
	Optional accessories	Cards: SNMP, USB, RS485 ModBus, dry contact relays		
	Compatible software platforms	Microsoft Windows, Linux, Mac OS, VMware		
REGULATIONS	Standards	IEC EN 62040-1, IEC EN 62040-2, IEC EN 62040-3		
	Marking	CE, UKCA		

\* Depending on the load    \*\* Battery weight and configuration depends on the required uptime    \*\*\* To be verified according to the battery parameters

## Control and management software

### UPS monitoring and management

The main features of the PowerMaster software, which is available free of charge at [www.ablerex.eu/download](http://www.ablerex.eu/download), are:

- installation and configuration via USB or RS232 serial port;
- orderly, automatic closure of the applications and operating system, even if the user is not there;
- UPS monitoring and power supply event reporting;
- transmission of alarms for the most common power supply problems and notification of system shutdown by email and text message;
- automatic testing of UPS and battery;
- available for Microsoft, MAC and Linux (full list available at [www.ablerex.eu/download](http://www.ablerex.eu/download)).

### Communication cards and software

Ablerex single-phase online UPS units offer maximum control thanks to optional communication cards:

- the SNMP network card enables you to monitor the status of the UPS from any PC or server connected to the LAN without having to install any specific software, thanks to the Web Server function, or remotely by means of a VPN connection. You can also manage automatic shutdowns of the devices connected to the UPS;
- the relay card with potential-free contacts transmits alarms remotely;
- the RS485 Modbus card effectively communicates the status of the UPS with the most widely used BMS systems.

## SNMP control and management

Manage the shutdown of all devices connected to the network with IP by means of remote control software (Generex RCCMD for the SNMP GEN and SNP GEN P cards and Ablerex ClientMate for SNMP ABL) compatible with Microsoft Windows (for desktops and servers), Linux, Apple MAC OS, VMware and others.

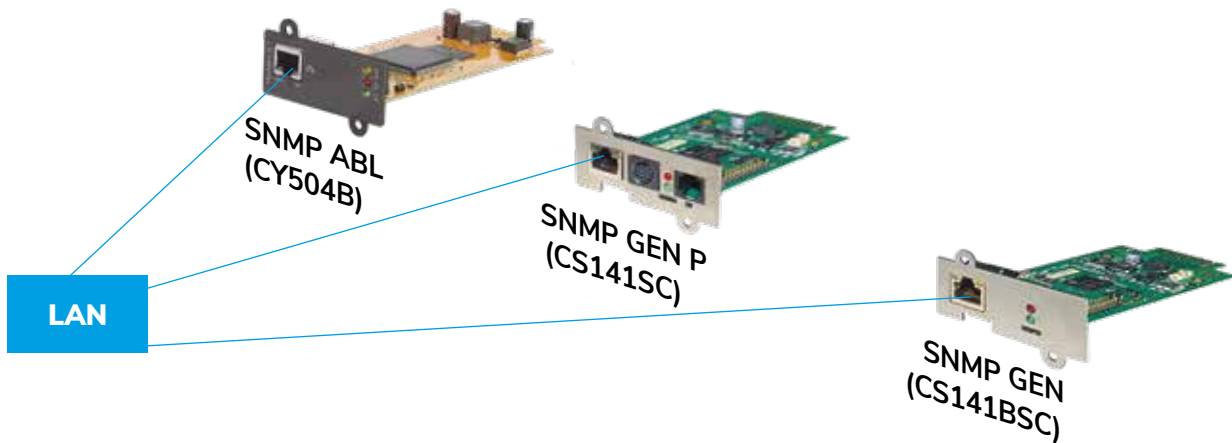

## Seamless integration with other network programs and SNMP management systems

### SNMP ABL • SNMP GEN • SNMP GEN P

HTTP/HTTPS interface • MIB • SNMP trap • Email notifications • Log file recording • ModBus via IP

### SNMP GEN • SNMP GEN P

Updating of SFTP configuration • BACnet

### SNMP GEN P

Notification by SMS • ModBus/Profibus on RS232/485

## Accessories

### Single-phase online UPS

#### COMMUNICATION CARDS for sending the CPSS status to a control computer

	<b>DCE-C:</b> Programmable card with dry contacts client software is included suitable for Ares, Odin and Mars.
	<b>SNMP ABL:</b> Network card CY504B for sending data, controlling UPS and receiving alarms via email with SNMP protocol. Suitable for Ares, Odin and Mars. Client software is included.
	<b>SNMP ABL E:</b> External network card for sending data (DY522), UPS control and reception of alarms via email with SNMP protocol, suitable for Ares, Odin and Mars. Client software is included.
	<b>SNMP GEN P:</b> 3-port GenereX card (CS141SC) for controlling UPS and receiving alarms via SMS or/ and email. Includes network interface for sending data with SNMP protocol, port for environmental monitoring sensor connection or RS232 adapter (ModBus or GPRS/GSM modem), and port connecting alarm contacts. Suitable for Ares, Odin and Mars. One RCCMD client software is included.
	<b>SNMP GEN:</b> Network card (CS141BSC) for UPS control, sending data, and reception of alarms via email, via SNMP protocol. Suitable for Ares, Odin and Mars. One RCCMD client software license is included.
	<b>RS485 card:</b> Card for data exchange via RS-485 via ModBus protocol, suitable for ARES and Odin.

#### PDU to ensure an energy supply to several devices

	<b>ESB-216:</b> External socket box with switch (2 x 16A IEC and 8 x 10A IEC) suitable for Mars 6000 kVA.
	<b>ESB-217:</b> External socket box with switch (9 x 10A IEC) suitable for Mars and Odin.
	<b>ESB-218:</b> External socket box with switch (4 x 16A IEC) suitable for Mars and Odin.
	<b>ESB-219:</b> External socket box with switch (9 x 10A IEC and 5 x 16A IEC) for Mars.

#### EXTERNAL BYPASS to ensure power continuity during service operations and simplified and safe maintenance

	<b>Rack_PDU-216G:</b> External manual bypass with additional sockets (6 x 10A IEC and 2 x 16A IEC) suitable for Ares, Odin RT. Dim. 440 x 77 x 87 mm. Weight 2,7 kg.
	<b>Rack-BP_PDU-50:</b> External manual bypass with additional 50A socket (4 x 16A IEC and 8 x 10A IEC) suitable for Mars. Dim. 440 x 120 x 175 mm. Weight 5 kg.
	<b>MTBS-60:</b> 60A maintenance bypass panel, suitable for Mars, max 2 x 6 kVA o 1 x 10 kVA. Dim 440 x 176 x 124 mm. Weight 5 kg.
	<b>MTBS-120:</b> 120A maintenance bypass panel, suitable for Mars, max 3 x 6 kVA o 2 x 10 kVA. Dim 440 x 176 x 124 mm. Weight 5 kg.
	<b>MTBS-200:</b> 200A maintenance bypass panel, suitable for Mars, max 4 x 6 kVA o 3 x 10 kVA. Dim 440 x 176 x 124 mm. Weight 5 kg.

#### PARALLEL KIT to share the load among more than one UPS to increase capacity and redundancy

	<b>Parallel kit 6k:</b> to connect two 6 kVA 2 UPS units with the included RJ cable, suitable for Mars.
	<b>Parallel kit 10k:</b> to connect two 10 kVA 2 UPS units with the included RJ cable, suitable for Mars.

#### ISOLATION TRANSFORMERS

for protection against electric shocks and ensure power availability to sensitive equipment

	<b>TRAFO06:</b> Isolation transformer for 6 kVA, suitable for Mars tower.
	<b>TRAFO10:</b> Isolation transformer for 10 kVA, suitable for Mars tower.

# THREE-PHASE UPS



Versatile high-power technology for critical applications



**KR Plus**  
10-40 kVA



**KR Plus XL**  
10-40 kVA



**TS**  
10-80 kVA



**TT**  
100-500 kVA



**TT GT**  
100-800 kVA

### Continuous power supply in the presence of regenerative loads

Traditional UPS systems often fail when faced with energy returning from the load. The KR UPS, however, ensures a continuous power supply to the protected load even in the presence of regenerative energy.



**The problem:** many industrial machines, including elevators, are powered by electric motors that frequently start and stop. During deceleration, these motors produce regenerative energy. If unmanaged, this regenerative load can cause over-voltage, damaging critical equipment and reducing the efficiency of industrial operations. Specifically, regenerative energy causes the dc bus to over-voltage in conventional UPS systems, leading them to cease operation.

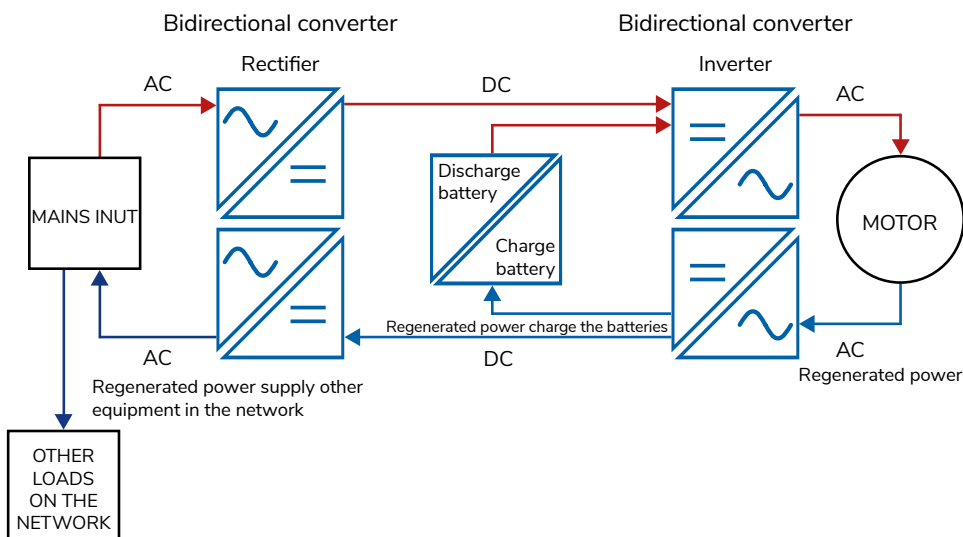

- **Complete solution for regenerative energy management (glm)**  
Patented solution, easily activated via software, this solution provides comprehensive management of regenerative energy.
- **Robust hardware**  
The bidirectional design of the KR UPS converters ensures hardware durability.

- **Eco-friendly**  
Reuse up to 90% of the energy produced by regenerative loads.
- **No oversizing needed**  
No need to oversize UPS power or battery capacity. The battery voltage remains controlled, and the load stays protected.



# KR PLUS - KR PLUS XL

- PF 1 ensures maximum power availability: kVA=KW for KR Plus 10-15-20-30-40 TTS.
- The patented GLM® function enables efficient management and reuse of energy produced by regenerative loads (e.g., elevators, electric motors, CNC machines, etc.).
- Compatible with lithium-ion batteries or other technologies.
- THDi <3% for low impact on the mains supply.
- The internal backfeed contactor integration eliminates the need for an external contactor.
- All models make it possible to maximize the energy available for loads with frequencies other than those of the power grid without loss of performance.
- Cold start function included.
- Designed to minimise impact on generators and avoid the need for overdimensioning them.
- Up to 95% efficiency in online mode.
- Internal manual bypass and 4-pole switches.
- Vertical internal layout ensures easy maintenance.
- Fail-safe: the UPS indicates when the phase sequence is connected incorrectly without interrupting the supply from the inverter to the loads, while keeping the batteries charged.
- High overload capacity for up to 1 minute at 150% load.
- Built-in high performance charger (10 kVA with standard charger for up to 10 A)
- Variable battery configuration: 26 to 40 individual 12V blocks settable from the touch display.
- Up to 6 units can be connected in parallel for power or redundancy, settable from the touch display
- Separate or common batteries that can be configured for parallel systems.
- 4.3" colour LCD touch screen display for user-friendly interface (14 selectable languages).
- Wide range of communication options included: two ports as standard, 1xRS232 and 1xUSB, programmable dry contacts plus two additional slots for optional cards.
- Log file for up to 800 events, and UPS information and settings can be easily downloaded to an SD card.

## Key options

- SNMP, RS485 ModBus and relay card with dry contacts.
- Parallel kit.
- Removable internal battery compartments for easy battery maintenance.
- External temperature sensor for a battery cabinet.
- Movable touch panel 7" with 3 programmable dry contacts for remotely monitoring up to 64 units.
- Internal backfeed contactor.



## UPS event logs and settings can be easily exported to SD-Card

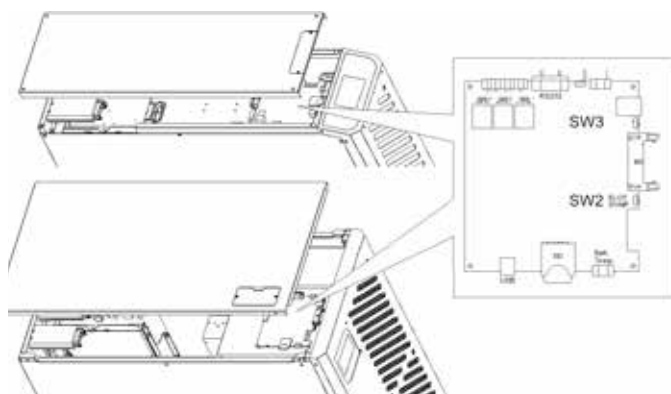

## Instant disconnected battery warning



# KR PLUS - KR PLUS XL

Lithium ready technology, maximum efficiency and versatility with the smallest footprint in its class.

## KR PLUS 10-40 kVA

UPS with PF1 (kVA=kW)  
provides the highest efficiency  
with the smallest footprint

The smallest footprint in its class (0.22 m<sup>2</sup> for 20 kVA with 40x9 Ah internal batteries) and its vertical internal layout ensure a low TCO.

Two interchangeable versions, 3:3 or 3:1-3, can easily be selected on-site (for 10, 15 and 20 kVA) for maximum installation flexibility.

Internal battery up to 40 x 9 Ah (for 10, 15 and 20 kVA).

## KR PLUS XL 10-40 kVA

Compact and versatile UPS  
with easily configurable  
single- or three-phase output

Flexible and compact design suitable for various configurations.

Long autonomy time thanks to the high number of integrated batteries. Up to 160 internal batteries (120 for 30/40Kva versions)

Thanks to the vertical internal layout of the components, maintenance, board replacement and scheduled battery change activities are simplified.

KR Plus XL range allows for the installation of an internal isolation transformer for input and output.



### Applications

- Server rooms
- Micro and mini data centres
- Telecommunications equipment
- Electromedical equipment
- Industrial applications
- Ideal for generators

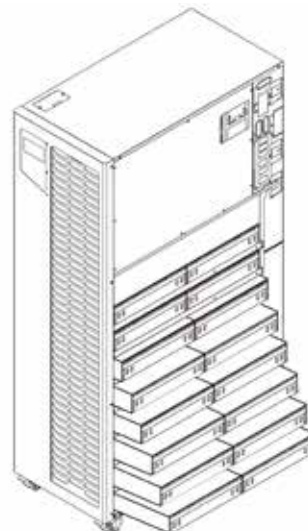

High internal battery  
density

## Easy and efficient commissioning and maintenance thanks to the Smart ageing self-test function

- The test function is able to monitor performance over time to identify potential deterioration in the various UPS components.
- More than 90% energy saving thanks to the possibility of performing verification tests without a real load.
- Possible to set up automatic on-site testing at any time: before commissioning or during UPS maintenance.
- Components can be tested by simulating different load conditions without a real load.

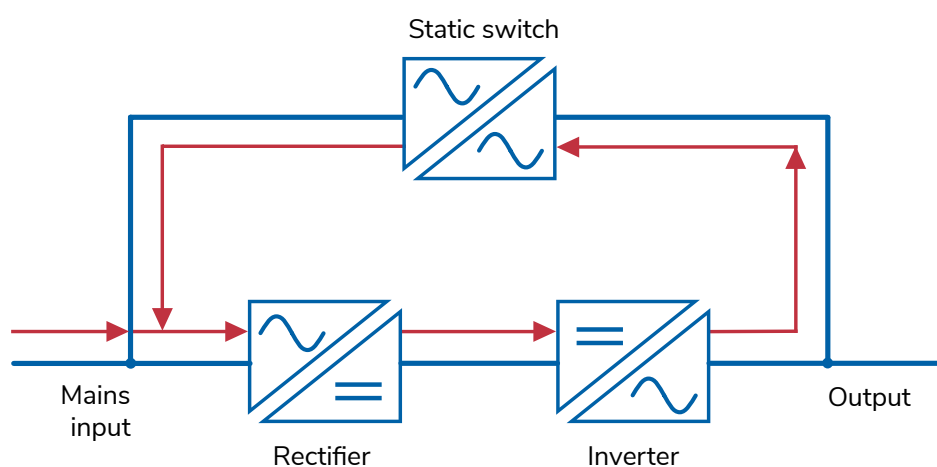

KR  
10/15/20 kVA 3/1



KR PLUS  
10/15/20 kVA



KR PLUS  
30/40 kVA



KR PLUS XL  
10/15/20 kVA



KR PLUS XL  
30/40 kVA



## KR PLUS - KR PLUS XL

## KR PLUS - KR PLUS XL TECHNICAL DATA SHEET

MODEL*		KR10D 3/1	KR15D 3/1	KR20D 3/1	KR10S Plus	KR15S Plus	KR20S Plus	KR30S Plus	KR40S Plus	
POWER	KVA	10	15	20	10	15	20	30	40	
	KW	9	13,5	18	10	15	20	30	40	
INPUT	Rated Voltage	400V three-phase+neutral								
	Voltage Tolerance	±20% @100% load, -40/+20% @50% load								
	Rated frequency	40 - 70 Hz								
	Power Factor	≥ 0,99								
	Current distortion (THDi)	3/1	≤ 5% at full load		≤ 3% at full load					
OUTPUT	Rated voltage	3/1	220/230/240 V single-phase+neutral		380/400/415 V three-phase+neutral					
		3/3	380/400/415 V three-phase+neutral							
	Voltage stability	±1% (static load)								
	Frequency	50/60 Hz								
	Frequency stability	±0,01% (free running)								
	Power factor	0.9				1				
	Crest factor	3:1								
	Voltage distortion	≤2% with linear load, ≤5% with distorting load								
	Overload	110% for 60 minutes, 125% for 10 minutes, 150% for 1 minute								
	BATTERY	Number per string (batt 12V)	26-40 config.	32-40 configurable		26-40 config.	32-40 configurable			
Max. charging current**		10 A	15 A	21 A	10 A	15 A	21 A	30 A	39 A	
Common battery for parallel configuration		Supported								
Max internal battery quantity		Standard	40 batteries 12V/7-9 Ah						N.A.	
	XL	160 batteries 12V/7-9 Ah					120 batteries 12V 7/9 Ah			
EFFICIENCY	VFI mode	Up to 95%								
	ECO mode	Up to 98%								
	In battery	Up to 94%								
BYPASS	Rated voltage	3/1	220/230/240 V single-phase+neutral		380/400/415 V three-phase+neutral					
		3/3	380/400/415 V three-phase+neutral							
	Voltage tolerance	Basic window ±10% (programmable ±5% - ±15%) Critical window ±25% (programmable ±16% - ±30%)								
	Frequency	50/60 Hz								
Frequency tolerance	±1 Hz / ±3 Hz (selectable)									
GENERAL	Parallel connection	Up to 6 units								
	Dimensions (WxDxH) mm	Standard	260x850x890							
		XL	440x850x1570							
	Weight (kg)	Standard	74	76	76	74	76	76	85	88
		XL					142	144	144	145
Grado di protezione	IP 20									
CONNECTIVITY	User interface	4.3" colour LCD touch screen display with removable SD card								
	Built-in communication ports	USB, RS232, EPO, 1 in/3 out dry contact relays (programmable) and additional slots for optional cards								
	Optional accessories	Cards: SNMP, RS-485 ModBus, 6 in/6 out dry contact relays, touch panel for remote monitoring								
ENVIRONMENTAL PARAMETERS	Operating temperature***	0-40°C								
	Relative humidity	0-95% (non-condensing)								
	Altitude (a.s.l.)	<1000 m with no power derating, >1000 m with 1% derating for every 100 m.								
	Audible noise at 1 m.	<52 dBA						<55 dBA		
REGULATIONS	Standards	IEC EN 62040-1, IEC EN 62040-2, IEC EN62040-3								
	Marking	CE, UKCA								

\*Models KRD: dual inputs (3/3 or 3/1); Models KRS: single input (3/3) \*\* Subject to conditions \*\*\* To be verified according to the battery parameters

# TS

- The patented GLM function can reuse energy regenerated by the loads, ensuring maximum efficiency when managing regenerative loads.
- Optimised footprint for maximum installation versatility.
- Designed to minimise impact on generators and avoid the need for overdimensioning them.
- Power factor of 1 (kW = kVA): maximum active power available for your system at all times.
- Fail-safe: the UPS indicates when the phase sequence is connected incorrectly without interrupting the supply from the inverter to the loads, while keeping the batteries charged.
- Up to 6 units can be connected in parallel for power or redundancy.
- The “Energy Saver” function dramatically reduce the facility power and cooling costs..
- Dual input and internal manual bypass.
- High overload capacity for up to 3 seconds at 300% load.
- High-performance battery charger for fast, efficient battery charging.
- Variable battery configuration can be set from the LCD.
- Compatible with lithium-ion batteries or other technologies.
- Smart battery discharge test without the need for external loads.
- Real-time battery disconnection alarm.
- Cold start (up to 20 kVA standard, up to 80 kVA optional).
- Separate or common batteries that can be configured for parallel systems.
- Wide range of communication options included: two ports as standard (RS232 and USB), programmable dry contacts plus two additional slots for optional cards.
- 4.3” colour LCD touch screen display for user-friendly interface (14 selectable languages).
- UPS information, settings and log files can be downloaded to a removable SD card.

## Key options

- SNMP, RS485 ModBus and relay card with dry contacts.
- Parallel kit.
- Removable internal battery compartments for easy battery maintenance.
- External temperature sensor for a battery cabinet.
- Movable touch panel 7” with 3 programmable dry contacts for remotely monitoring up to 64 units.
- Internal backfeed contactor.



## Ideal for generators

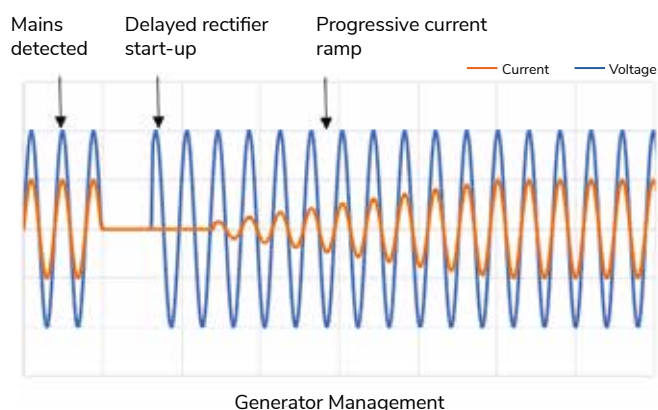

## TS

### TS 10-80 kVA

State-of-the-art technology for a high performance three-phase UPS

Its power factor of 1 (kW = kVA) and easy maintenance reduce system TCO, making Taurus the best choice for data centres.



### Applications

- Data centres
- Electromedical equipment
- Industrial applications
- Regenerative loads (lifts, cranes, numerically controlled machines, etc.)

TS  
10/20 kVA

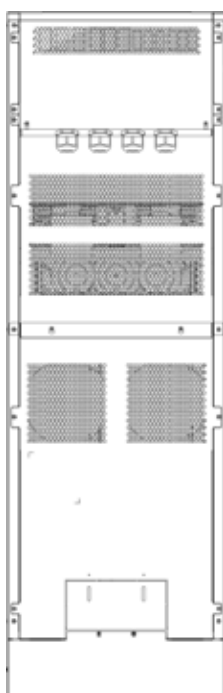

TS  
30/40 kVA

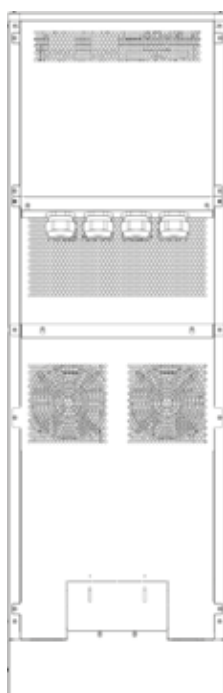

TS  
60/80 kVA

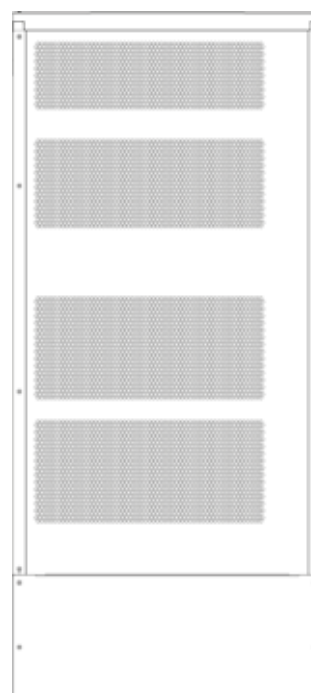

## TS TECHNICAL DATA SHEET

MODEL		TS 10kVA	TS 20kVA	TS 30kVA	TS 40kVA	TS 60kVA	TS 80kVA
POWER	kVA	10	20	30	40	60	80
	kW	10	20	30	40	60	80
INPUT	Rated voltage	380/400/415 Vac three-phase with neutral					
	Voltage tolerance	±20%					
	Rated frequency	40 – 70 Hz					
	Power factor	≥0.99					
	Current distortion (THDi)	<3%					
OUTPUT	Rated voltage	380/400/415 V three-phase with neutral					
	Voltage stability	±1% (static load)					
	Frequency	50/60 Hz					
	Frequency stability	±0.01% (free running)					
	Power factor	1					
	Crest factor	3:1					
	Voltage distortion	<1% with linear load, <3% with distorting load					
	Permissible overload	110% for 60 minutes, 125% for 10 minutes, 150% for 1 minute, >150% and <300 for 3 seconds					
BATTERY	Number per string (batt 12V)	26 – 40 conf.		32 – 40 configurable			
	Max. charging current *	10 A	21 A	30 A	39 A	60 A	78 A
	Common battery for parallel configuration	Supported					
	Internal battery (optional)	Up to 80 12 V 7/9 Ah battery blocks					N.A.
EFFICIENCY	VFI mode	Up to 96%					
	ECO mode	Up to 98%					
BYPASS	Rated voltage	380/400/415 V three-phase + neutral					
	Voltage tolerance	±5% – ±25% (programmable alarm)					
	Frequency	50/60 Hz					
	Frequency tolerance	±1 Hz/±3 Hz (selectable)					
GENERAL	Dimensions (WxDxH) mm	440x860x1390				600x827x1300	
	Weight (kg)	84	86	130	132	200	210
	Protection class	IP20					
	Cold start from the battery without mains power	Included			Optional		
	Parallel connection	Up to 6 units					
CONNECTIVITY	User interface	4.3 " colour LCD touch screen display with removable SD card					
	Built-in communication ports	USB, RS232, EPO, 1 in/3 out dry relay contacts (programmable) and additional slots for optional cards					
	Optional accessories	Cards: SNMP, RS485, ModBus, 6 in/6 out dry relay contacts (programmable), touch panel for remote monitoring of up to 64 units					
ENVIRONMENTAL PARAMETERS	Operating temperature**	0 – 40°C					
	Relative humidity	0 – 95% (without condensing)					
	Altitude (a.s.l.)	<1000 m with no power derating, >1000 m with 0.5% derating for every 100 m.					
	Audible noise at 1 m.	<52 dBA		<55 dBA		<60 dBA	
REGULATIONS	Standards	IEC EN 62040-1, IEC EN 62040-2, IEC EN 62040-3					
	Marking	CE, UKCA					

\* Subject to conditions    \*\* To be verified according to the battery parameters

# THREE-PHASE UPS

## TT - TT GT

- Power factor of 1 (kW = kVA) and up to 96% efficiency in VFI mode (up to 99% ECO mode).
- THDi <3% to minimise impact on the mains supply.
- Designed to minimise impact on generators and avoiding the overdimension.
- Power capacitive and inductive loads with no derating.
- Front access for very easy maintenance.
- Ideal for applications that require long back-up uptime. Battery charge current regulation via firmware.
- Neutral disconnect for safe maintenance.
- Dual input and internal manual bypass.
- Up to 6 units can be connected in parallel for power or redundancy.
- Separate or common batteries for parallel systems.
- Battery Care system increases battery life by regulating the charge according to the manufacturer's instructions and minimising the ripple current.
- Wide range of communication options included: two ports as standard (RS232 and USB) and two additional slots for optional cards.
- Wide LCD display 100 kVA to 500 kVA.

### Key options

#### TITAN

- Programmable dry contacts.
- Common batteries for parallel systems.
- SNMP, RS485, ModBus cards and temperature probe.
- Colour touch screen display for power from 100 to 160 kVA.
- Remote monitoring panel.
- External manual bypass for maintenance
- Parallel kit

#### TITAN GT

- Isolation transformer and autotransformer for bypass and/or input line.
- Battery charging voltage compensation based on the temperature.
- Redundant loop parallel communication.
- Load-sync for single or parallel UPS.
- External manual bypass for maintenance
- Parallel kit

### Dynamic charging mode function

Thanks to this function, all available power not absorbed by the load can be used to quickly charge batteries, including those sized for long autonomies.

The function, which can be activated by the firmware, allows the charging current of the batteries to be adjusted.

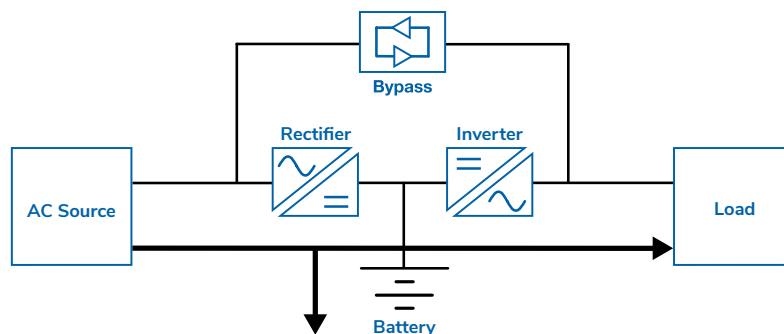



## TT 100-500 kVA

Titan offers maximum protection and efficiency in a compact design, while ensuring absolute power continuity in all critical applications



## TT GT 100-800 kVA

With its built-in transformer with galvanic isolation, Titan GT offers maximum protection and efficiency with the lowest running cost



### Applications

- Data centres
- Electromedical equipment
- Industrial applications

Ideal for generators

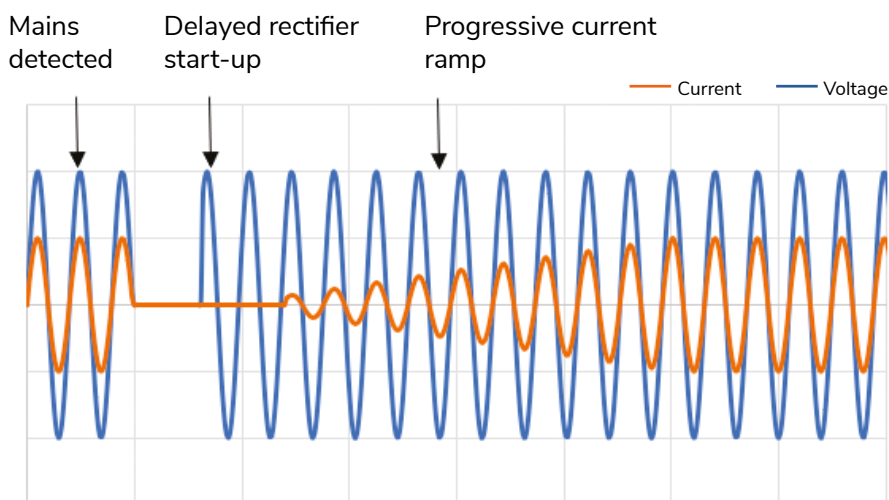

Regenerative load management

### TT TECHNICAL DATA SHEET

MODEL		TT 100kVA	TT 125kVA	TT 160kVA	TT 200kVA	TT 250kVA	TT 300kVA	TT 400kVA	TT 500kVA	
POWER	kVA	100	125	160	200	250	300	400	500	
	kW	100	125	160	200	250	300	400	500	
INPUT	Rated voltage	400 Vac three-phase with neutral								
	Voltage tolerance	-20% to +15%								
	Rated frequency	45 to 65 Hz								
	Power factor	>0.99								
	Current distortion (THDi)	<3%								
OUTPUT	Rated voltage	380/400/415 Vac three-phase with neutral								
	Voltage stability	±1% (static)								
	Frequency	50/60 Hz								
	Frequency stability	±0.001 (free running)								
	Power factor	1								
	Crest factor	3:1								
	Voltage distortion	<1% with linear load, <5% with distorting load								
	Permissible overload*	125% for 10 minutes, 150% for 30 seconds			125% for 5 minutes, 150% for 30 seconds					
BATTERY	Number per string (12V)	60 – 62 configurable								
	Max. charging current	Up to 50 A			Up to 120 A					
	Common batteries for parallel configuration	Supported								
EFFICIENCY	VFI mode	Up to 96%								
	ECO mode	Up to 98%								
BYPASS	Rated voltage	380/400/415 Vac three-phase with neutral								
	Voltage tolerance	±10% (selectable)								
	Frequency	50/60 Hz (selectable)								
	Frequency tolerance	±10 Hz (selectable)								
GENERAL	Parallel connection	Up to 6 units								
	Dimensions (WxDxH) mm	560x940x1800			880x970x1978			1430x970x1978		
	Weight (kg)	320	360	380	720	850	930	1080	1250	
	Protection class	IP20								
CONNECTIVITY	User interface	LCD display, LED synoptics and keyboard			Colour touch screen display					
	Built-in communication ports	USB, RS232, EPO, auxiliary contact for battery switch, auxiliary contact for external manual bypass, diesel mode contact and two additional slots for optional cards.								
	Optional accessories	Cards: SNMP, RS485, ModBus, dry relay contacts, remote monitoring panel.								
ENVIRONMENTAL PARAMETERS	Operating temperature**	0 – 40°C								
	Relative humidity	0 – 95% (without condensing)								
	Altitude (a.s.l.)	<1000 m with no power derating, >1000 m with 0.5% derating for every 100 m.								
	Audible noise at 1 m.	<60 dBA								
REGULATIONS	Standards	IEC EN 62040-1, IEC EN 62040-2, IEC EN 62040-3								
	Marking	CE, UKCA								

\* Subject to conditions    \*\* To be verified according to the battery parameters

## TT GT TECHNICAL DATA SHEET

MODEL		TT GT 100-125-160 kVA	TT GT 200-250-300 kVA	TT GT 400kVA	TT GT 500kVA	TT GT 600kVA	TT GT 800kVA
POWER	kVA	100 / 125 / 160	200 / 250 / 300	400	500	600	800
	kW	90 / 112.5 / 144	180 / 225 / 270	360	450	540	720
INPUT	Rated voltage	400 Vac three-phase with neutral					
	Voltage tolerance	-20% to +15%					
	Rated frequency	45 to 65 Hz					
	Power factor	0.99					
	Current distortion (THDi)	<3%					
OUTPUT	Rated voltage	380/400/415 Vac three-phase with neutral					
	Voltage stability	±1% (static)					
	Frequency	50/60 Hz					
	Frequency stability	±0.001 (free running)					
	Power factor	0.9					
	Crest factor	3:1					
	Voltage distortion	<1% with linear load, <5% with distorting load					
	Permissible overload	125% for 10 minutes, 150% for 1 minute					
BATTERY	Number per string (12V)	50/52 configurable					
	Max. charging current *	Up to 100 A					Up to 200 A
EFFICIENCY	VFI mode	Up to 95%					
	ECO mode	Up to 98%					
BYPASS	Rated voltage	380/400/415 Vac three-phase with neutral					
	Voltage tolerance	±10% (selectable)					
	Rated frequency	50/60 Hz (selectable)					
	Frequency tolerance	±10 Hz (selectable)					
GENERAL	Parallel connection	Up to 6 units					
	Dimensions (WxDxH) mm	815x825x1670	1200x860x1900	1990x990x1920	2430x990x2020	2440x990x2020	3640x990x1920
	Weight (kg)	100 kVA = 625 125 kVA = 660 160 kVA = 715	200 kVA = 970 250 kVA = 1090 300 kVA = 1170	1820	2220	2400	3600
	Protection class	IP20					
CONNECTIVITY	User interface	LCD display, LED synoptics and keyboard					
	Built-in communication ports	USB, RS232, EPO, auxiliary contact for battery switch, auxiliary contact for external manual bypass, diesel mode contact and two additional slots for optional cards.					
	Optional accessories	Cards: SNMP, RS485, ModBus, dry relay contacts, remote monitoring panel.					
ENVIRONMENTAL PARAMETERS	Operating temperature**	0 – 40°C					
	Relative humidity	0 – 95% (without condensing)					
	Altitude (a.s.l.)	<1000 m with no power derating, >1000 m with 0.5% derating for every 100 m.					
	Audible noise at 1 m.	<62 dBA					
REGULATIONS	Standards	IEC EN 62040-1, IEC EN 62040-2, IEC EN 62040-3					
	Marking	CE, UKCA					

\* Subject to conditions \*\* To be verified according to the battery parameters

## Control and management software

### Communication cards and software

Ablerex three-phase online UPS units offer maximum control thanks to optional communication cards:

- the SNMP network card enables you to monitor the status of the UPS from any PC or server connected to the LAN without having to install any specific software, thanks to the Web Server function, or remotely by means of a VPN connection. You can also manage automatic shutdowns of the devices connected to the UPS;
- the relay card with potential-free contacts transmits alarms remotely;
- the RS485 Modbus card effectively communicates the status of the UPS with the most widely used BMS systems.

## SNMP control and management

Manage the shutdown of all devices connected to the network with IP by means of remote control software (Generex RCCMD for SNMP GEN card and Ablerex ClientMate for the TS-KR-SNMP-1 card), compatible with Microsoft Windows (for desktops and servers), Linux, Apple MAC OS and VMware.

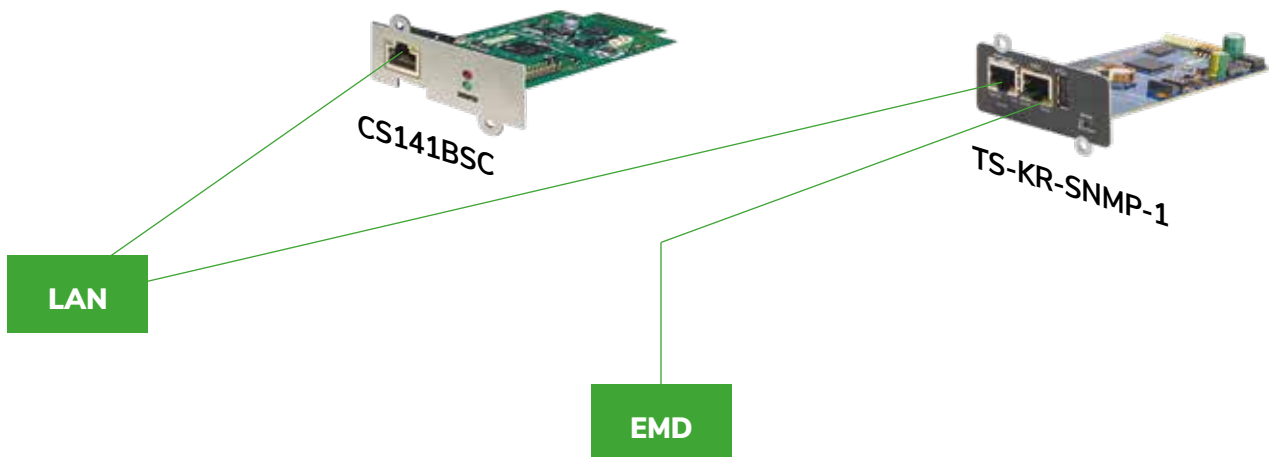

### Seamless integration with other network programmes and SNMP management systems

#### TS-KR-SNMP-1 • SNMP GEN

- HTTP interface • Network message • SNMP trap
- Email notifications • Log file recording
- Notification by text message • Modbus over IP

#### CS141BSC • CS141MINI

- BACnet
- SFTP configuration update

### Power communication function extensions (COM2)

- SensorManager temperature and humidity monitoring
- Selectable alarm thresholds
- Data transmission from the SM\_T\_COM temperature sensor
- Data transmission from the SM\_T\_H\_COM humidity sensor

## Accessories

### Three-phase monolithic UPS

**COMMUNICATION CARDS** for sending the UPS status to a control computer

<b>TS-KR-SNMP-1:</b> Communication card with SNMP protocol with client software included.
<b>SNMP GEN:</b> Communication card (CS141BSC) with SNMP protocol with client software included.
<b>TS-KR-EMD:</b> Environmental monitoring sensor for SNMP card (temperature and humidity).
<b>TS-KR-485:</b> Card for data exchange via RS-485 with ModBus protocol
<b>TS-KR-DEC:</b> 6 in 6 out programmable relay card with dry contact signal.

**ACCESSORIES FOR MONITORING INTERNAL BATTERY TRAYS** to increase uptimes

<b>TRAY 32-40:</b> Tray for battery blocks (each tray can contain up to 40 blocks), for TAURUS from 10 to 40 kVA.
---

**COLD START KIT** to allow the UPS to start from batteries without mains power

<b>CS30kVA:</b> Contactor and cables, kit suitable for 30 kVA Taurus.
<b>CS40kVA:</b> Contactor and cables, kit suitable for 40 kVA Taurus.
<b>CS60kVA:</b> Contactor and cables, kit suitable for 60 kVA Taurus.
<b>CS80kVA:</b> Contactor and cables, kit suitable for 80 kVA Taurus.

**EXTERNAL BY-PASS**

it enables the UPS system to be electrically isolated – taken it out of the critical power circuit – for safe UPS maintenance or unit replacement.

<b>BYPASS 10 3/1:</b> By-pass box x 10 kVA 3/1.
<b>BYPASS 20 3/1:</b> By-pass box x 20 kVA 3/1.
<b>BYPASS 20 3/3:</b> By-pass box x 20 kVA 3/3.
<b>BYPASS 40 3/3:</b> By-pass box x 40 kVA 3/3.
<b>BYPASS 60 3/3:</b> By-pass box x 60 kVA 3/3.
<b>BYPASS 80 3/3:</b> By-pass box x 80 kVA 3/3.
<b>BYPASS 250 3/3:</b> By-pass box x 250 kVA 3/3.
<b>BYPASS 400 3/3:</b> By-pass box x 400 kVA 3/3.

**BACKFEED PROTECTION** to ensure protection against a possible power backfeed from the mains.

<b>BF10kVA:</b> Internal backfeed contactor for 10 kVA Taurus.
<b>BF20kVA:</b> Internal backfeed contactor for 20 kVA Taurus.
<b>BF30kVA:</b> Internal backfeed contactor for 30 kVA Taurus.
<b>BF40kVA:</b> Internal backfeed contactor for 40 kVA Taurus.
<b>BF60kVA:</b> Internal backfeed contactor for 60 kVA Taurus.
<b>BF80kVA:</b> Internal backfeed contactor for 80 kVA Taurus.

**ISOLATION TRANSFORMERS**

<b>TRAFO10:</b> Transformer for 10 kVA Taurus and Kronos.
<b>TRAFO20:</b> Transformer for 20 kVA Taurus and Kronos.
<b>TRAFO30:</b> Transformer for 30 kVA Taurus and Kronos.
<b>TRAFO40:</b> Transformer for Taurus and Kronos 40 kVA.
<b>TRAFO60:</b> Transformer for 60 kVA Taurus.
<b>TRAFO80:</b> Transformer for Taurus 80 kVA.

**PARALLEL KIT AND CABLES** to share the load among more than one UPS to increase capacity and redundancy

<b>PARKIT TS:</b> Parallel kit composed of card and 1.5 m cable for Taurus.
<b>PARKIT KR:</b> Parallel kit composed of card and 1.5 m cable for Kronos.
<b>PARCAB30:</b> 3 m parallel cable for Kronos and Taurus.
<b>PARCAB80:</b> 8 m parallel cable for Kronos and Taurus.

**DUST FILTER**

<b>FILTERTS10-40:</b> Dust filter for 10 to 40 kVA Taurus.
--

## THREE-PHASE UPS

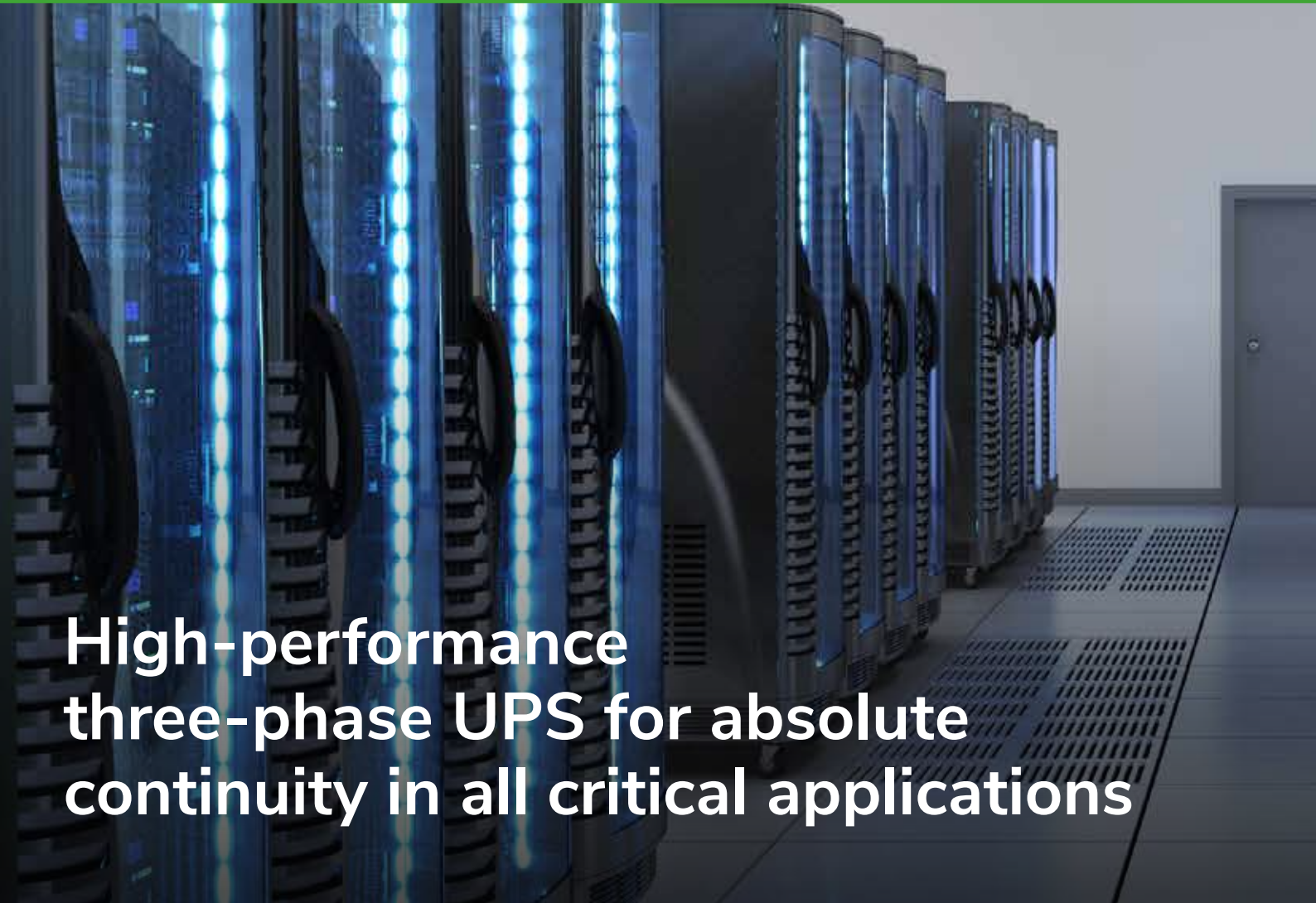



## THREE-PHASE UPS

### MD

- The high-density design with full hot-swap technology for both power and bypass modules ensures continuity and protects your load at all times.
- Power factor of 1 (kW = kVA): maximum active power available at all times.
- Very high efficiency (up to 99.3% in ECO Smart mode) for maximum energy saving: bypass and inverter work together to provide combined energy to the load and ensure zero transfer time in the event of a blackout.
- Up to 4 units can be connected in parallel (up to 3.6 MW) for power or redundancy.
- Long component life for a lower TCO (Total Cost of Ownership): the Energy Saver function automatically makes the power modules work in rotation to ensure greater efficiency and duration.
- Designed to minimise impact on generators and avoid overdimensioning them.
- Optimised footprint for maximum installation versatility to make installation possible in any type of environment.
- Easy installation thanks to the central bypass that ensures better load balance and lower risk of system overload.
- Variable battery string configuration can be set from the LCD for maximum installation flexibility.
- Minimum battery voltage can be set according to the discharge current, so the batteries can always be used in the best way to maximise their expected or lifespan life.
- High quality long-life capacitors (up to 10 years under favourable operating conditions).
- Cold start function included.
- Compatible with lithium-ion batteries or other technologies.
- Dual input for main power supply and bypass.
- Internal manual bypass.
- User-friendly LCD touch display with multi-language graphical user interface to have everything under control at all times.
- Event log can be downloaded directly from the LCD via USB port.
- Communication slots for optional card.
- RS485-ModBus, relay card with dry contact and USB port built-in.

### Key options

- Input, output and bypass breaker.
- Communication cards: Web SNMP.
- Isolation transformer.
- Additional battery charger for long uptimes.

Contact our offices for a complete list of accessories

### 60 kVA

#### Combo solution

- Up to 4 internal strings of 40 x 9 Ah batteries.
- Fuses to protect each string.



# MD 15-900 kVA

## High-performance three-phase modular UPS for absolute continuity in all critical applications

Fully scalable and high efficiency (99.6% in ECO mode), the Thor series based on 15, 25 and 75 kVA/kW modules guarantees energy saving and minimum TCO (Total Cost of Ownership).

### Applications

- Data centres: from micro to large
- Network Operations Centres (NOC)
- Security operations centres
- Telecommunications systems
- Broadcast and video streaming infrastructure
- Industrial automation control systems
- Remote teaching infrastructure
- Healthcare facilities

### Energy Saver: higher efficiency and lower TCO (Total Cost of Ownership)

The Energy Saver function ensures the modules last a long time by automatically making them work in rotation to balance component wear and increase their life.

### ECO Smart mode: higher energy savings and maximum availability of connected systems

In ECO Smart Mode (iECO), the bypass and inverter work together to provide combined energy.

This can achieve greater efficiency (up to 99.3) and ensure a transfer time of 0.

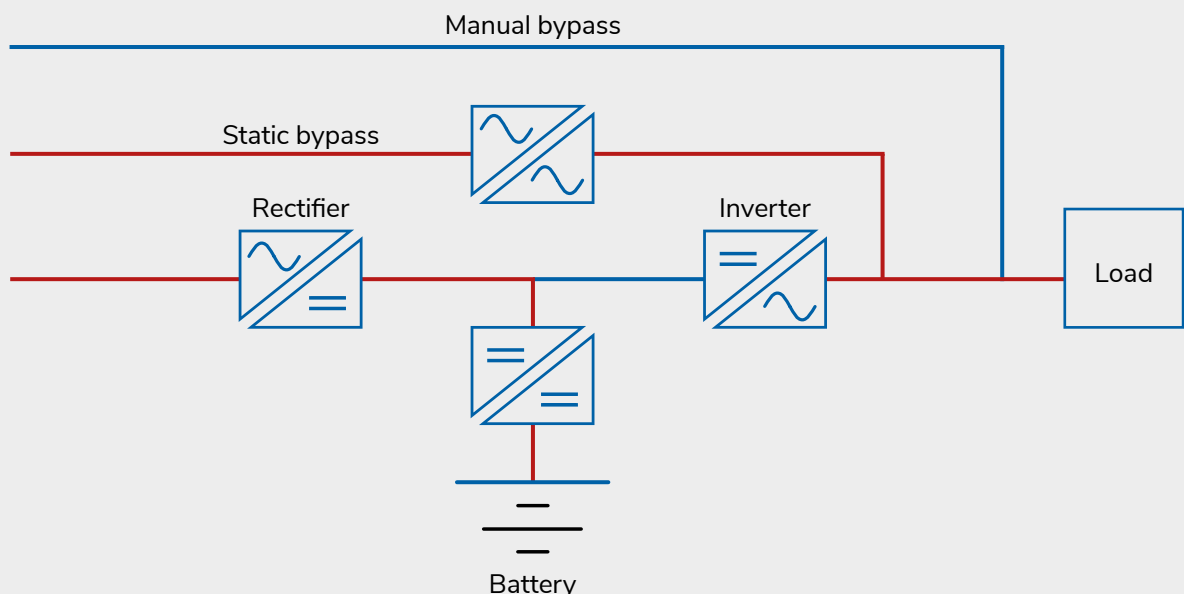

### MD TECHNICAL DATA SHEET

MODEL		MD 15-900									
POWER	kVA	15			25			75			
	kW	15			25			75			
INPUT	Rated voltage	400 Vac three-phase with neutral									
	Voltage tolerance	20% @100% load, -40% ~-20% @50% load									
	Rated frequency	40 – 70 Hz									
	Power factor	≥0.99									
	Current distortion (THDi)	<3%									
OUTPUT	Rated voltage	380/400/415 Vac three-phase with neutral									
	Voltage stability	±1% (static load)									
	Frequency	50/60 Hz									
	Frequency stability	±0.01% (free running)									
	Power factor	1									
	Crest factor	3:1									
	Voltage distortion	≤3% with linear load, ≤6% with distorting load									
	Permissible overload	110% for 60 minutes, 125% for 10 minutes, 150% for 1 second									
BATTERY	Battery cabinet	modular	classic								
	Battery architecture	modular, 4 strings	separate cabinet								
	Number per string (12V)	40	32–44 configurable				32–44 configurable				
	Max. charging current	3 A per module			5 A per module			15 A per module			
EFFICIENCY	VFI mode	up to 95.3%			up to 95.6%			up to 96%			
	ECO Smart mode	99.3%									
	Battery mode	up to 95.2%			up to 95.5%			up to 95.7%			
BYPASS	Rated voltage	380/400/415 V three-phase + neutral									
	Voltage tolerance*	-40% to +20% (selectable)									
	Frequency	50/60 Hz									
	Frequency tolerance	50/60 Hz±4%						50/60 Hz±6%			
GENERAL	Cabinet Model	MD COM-BO60-00 cabinet	MD R30-00	MD R60-00	MD R120-00	MD R150-00	MD R250-00	MD R450-00	MD R600-00	MD R900-00	
	Module power (kVA)	15			25			75			
	Power modules that can be installed	up to 4	up to 2	up to 4	up to 8	up to 6	up to 10	up to 6	up to 8	up to 12	
	Parallel connection	up to 4									
	Cabinet dimensions (WxDxH) mm	600x1100x2000	442x800x662	442x800x840	442x800x1195	600x1000x1600	600x1000x2000	900x1000x2000	1200x1000x2000	1800x1000x2000	
	Weight (Kg) **	444	120	164	263	284	410	650	800	1200	
	Protection class	IP20									
CONNECTIVITY	User interface	7" colour LCD touch screen									
	Built-in communication ports	USB, 1 additional slot, EPO, RS485-ModBus, RS232 GEN, BCB, 4 in/8 out relay with dry contacts				USB, 1 additional slot, EPO, BFP, RS485-ModBus, RS232 GEN, BCB, 4 in/8 out relay with dry contacts					
	Optional accessories	Cards: SNMP, battery temperature sensor									
ENVIRONMENTAL PARAMETERS	Operating temperature***	0 – 40°C									
	Altitude (a.s.l.)	<1000 m with no power derating, >1000 m with 1% derating for every 100 m.									
	Relative humidity	0 – 95% (without condensing)									
	Audible noise at 1 m.	<70 dBA									
REGULATIONS	Standards	IEC EN 62040-1, IEC EN 62040-2, IEC EN 62040-3									
	Marking	CE, UKCA									

\* Subject to conditions \*\* Includes empty battery modules for Thor Combo \*\*\* To be verified according to the battery parameters

## Accessories

### Three-phase modular UPS

#### DUMMY LOADS FOR GLM FUNCTION

<b>DUMMY 10:</b> dummy load for lift function 3 kW for TAURUS 10kVA.
<b>DUMMY 20:</b> dummy load for lift function 6 kW for TAURUS 20kVA.
<b>DUMMY 30:</b> dummy load for lift function 9 kW for TAURUS 30kVA.
<b>DUMMY 40:</b> dummy load for lift function 12 kW for TAURUS 40kVA.
<b>DUMMY 60:</b> dummy load for lift function 18 kW for TAURUS 60kVA.
<b>DUMMY 80:</b> dummy load for lift function 24 kW for TAURUS 80kVA.

**REMOTE PANEL** for Kronos, Taurus and all single phase double conversion, Monitor up to 64 UPS

#### COMMUNICATION CARDS

<b>MD-SNMP:</b> SNMP Card for THOR
<b>SNMP GEN Mini:</b> SNMP Generex CS141 mini
<b>TEMPEXT-TH:</b> External Battery Temperature Probe

#### INPUT BARS

<b>DUAL-TH-R30:</b> single source 30kVA
<b>DUAL-TH-R60:</b> single source 60kVA
<b>DUAL-TH-R120:</b> single source 120kVA
<b>DUAL-TH-R450:</b> single source 450kVA
<b>DUAL-TH-R600:</b> single source 600kVA
<b>DUAL-TH-R900:</b> single source 900kVA

#### PARALLEL KIT

<b>PARKIT2-TH:</b> Parallel Kit for 2 pcs UPS parallel
<b>PARKIT3-TH:</b> Parallel Kit for 3 pcs UPS parallel
<b>PARKIT4-TH:</b> Parallel Kit for 4 pcs UPS parallel

#### DISCONNECTORS

<b>BR-TH-R30:</b> Input/ bypass/output braeker for TH-R30. Dim. 442x800x662
<b>BR-TH-R60:</b> Input/ bypass/output braeker for TH-R60. Dim. 442x800x840
<b>BR-THCOMBO-R30:</b> Input/ bypass/output braeker for combo 30KVA. Dim. 442x800x662
<b>BR-THCOMBO-R60:</b> Input/ bypass/output braeker for combo 60KVA. Dim. 442x800x840
<b>BR-TH-R150:</b> Input/ bypass/output braeker for 150KVA. Dim. 600x1000x1600
<b>BR-TH-R250:</b> Input/ bypass/output braeker for 250KVA. Dim. 600x1000x2000
<b>BR-TH-R450:</b> Input/ bypass/output braeker for 450KVA. Dim. 1200x1000x2000
<b>BR-TH-R600:</b> Input/ bypass/output braeker for 600KVA. Dim. 1200x1000x2000
<b>BR-TH-R900:</b> Input/ bypass/output braeker for 900KVA. Dim. 1800x1000x2000

## SINGLE AND THREE-PHASE CPSS

Central Power Supply System,  
fully EN 50171 compliant  
certified by third party



**CPSS 1/1**  
4000-10000 VA



**CPSS 3/3**  
10-40 kVA

## CPSS

- **Fully EN 50171 compliant with third party test certificate**, the ZEN CPSS is a real Central Power Supply System that meets all legal requirements for the protection of emergency and safety systems.
- Easy to install: smallest footprint among EN 50171 compliant products.
- Wide variety of audible and visual alarms including: battery polarity reversal, CPSS and battery charger short circuit, power failure, low battery, bypass transfer, CPSS fault.
- Cold start from the battery without mains power.
- Maximum efficiency (up to 98%) and flexibility thanks to the 4 operating modes.
- The single-phase version includes mixed, online and SE modes with separate outputs, while the three-phase version requires optional accessories.
- Dual input and internal manual bypass for simple, completely safe maintenance.
- High overload capacity: delivers up to 120% of the rated power indefinitely.
- Easy and fast connection guaranteed by the terminals, which have been enlarged in the single-phase version.
- Option of internal battery with housing for 40 9Ah batteries for three-phase 10 and 20 kVA models (with optional tray kit only), giving a compact solution for small-load applications.
- Protection against load-side short circuits and battery polarity reversal, without the risk blowing fuses during commissioning, even in the event of reversal.
- Shorter charging time and longer battery life thanks to high charge current with temperature compensation.
- Accurate calculated remaining uptime is shown on the display.
- Hot-swappable batteries: the batteries can be replaced while the CPSS is running.
- Greater flexibility offered by the internal charger that is easy to set from the display.
- Battery life of 10 years.
- Heat and fire resistant IP20 casing that is EN 60598-1 compliant.
- Easily upgradeable firmware.
- RS232, USB and EPO ports built-in, and slots for optional communication cards. Remote on/off available in the single-phase version.



**Fully EN 50171 compliant with third party test certificate**

### Key options

- Cards: SNMP, RS485 ModBus and relay card with dry contacts
- EN 50272-2 compliant battery cabinet

### CPSS single-phase

- Additional battery charger for long runtimes

### CPSS three-phase

- Parallel kit
- Mixed mode kit

EN 50171 compliant CPSS designed to ensure the highest degree of protection in the critical environments of all emergency system installations.

For everyone's peace of mind: designers, retailers, installers and end users.

## CPSS single-phase 4000-10000 VA



## CPSS three-phase 10-40 kVA



### Applications

- Emergency lighting
- Fire alarm systems
- Smoke extraction systems
- Gas and smoke detection systems
- Security alarm systems
- PAV Voice Systems
- Lone Worker Systems

Single-phase  
CPSS 4-6 VA  
CPSS 8-10 VA

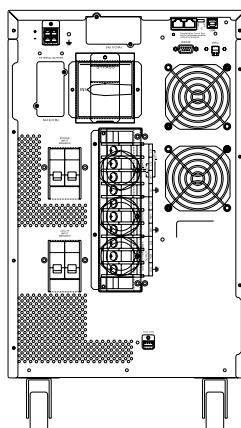

Three-phase  
CPSS 10-20 kVA

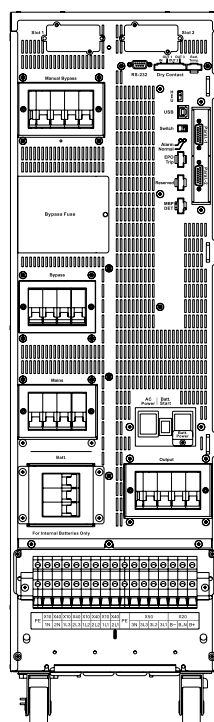

Three-phase  
CPSS 30-40 kVA

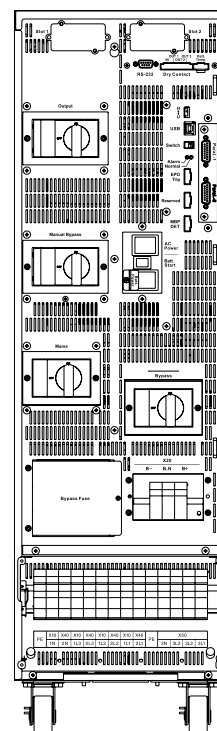

### CPSS SINGLE-PHASE TECHNICAL DATA SHEET

MODEL		CPSS 4000	CPSS 6000	CPSS 8000	CPSS 10000
POWER	VA	4000	6000	8000	10000
	W	3500	5250	7000	8500
INPUT	Rated voltage*	110 – 280 Vac			
	Frequency	45 – 70 Hz			
	Power factor	>0.99			
	Current distortion (THDi)	<5%			
OUTPUT	Rated voltage	200/208/220/230/240 Vac selectable			
	Voltage distortion	<2% with linear load, <7% with distorting load			
	Voltage stability	±1%			
	Frequency	50/60 Hz (selectable)			
	Frequency regulation	±1Hz, ±3Hz selectable			
	Frequency stability	≤ 0.2% (free running)			
	Power factor	0.875			0.85
	Crest factor	3:1			
	Waveform	Pure sine wave			
	Output connection	Screw terminal block			
	Capacity @ 100 % load	4000 VA/3500 W	6000 VA/5250 W	8000 VA/7000 W	10000 VA/8500 W
	Overload @ 120% permanent load	4200 VA/4200 W	6300 VA/6300 W	8400 VA/8400 W	10200 VA/10200 W
	EFFICIENCY	VFI mode	Up to 93%		
ECO mode		Up to 97%			
In battery		Up to 94%			
GENERAL	Dimensions (WxDxH) mm	288x700x513			
	Weight (kg)	41		42	
	Alarms	Audible and visual alarm alerts for: incorrect battery polarity, short circuit, power failure, low battery, bypass transfer, and UPS fault, etc.			
	Protection	Battery polarity, short circuit, overload, overheating, deep discharge, overcharging.			
	Operating mode	Multimode: VFI, ECO, Emergency (SE), Mixed mode (SA and SE with separate outputs)			
	Cold start from the battery without mains power	Included			
	Protection class	IP20			
	BATTERY - CHARGER	Battery type	12V VRLA, AGM (maintenance-free lead)		
Number of batteries		20 units (120 cells)			
Charging time		80% of the battery capacity within 12h			
Internal battery charger		4 A Standard (additional 4 A with optional kit)			
External battery cabinet connections		Plug-in & Play			
ENVIRONMENTAL PARAMETERS	Operating temperature**	0 – 40°C			
	Relative humidity	0% – 90% (without condensing)			
	Altitude (a.s.l.)	<1000 m with no power derating, >1000 m with 1% derating for every 100 m			
	Audible noise at 1 m	≤60 dBA			
CONNECTIVITY	Built-in communication ports	USB, RS232, EPO On/Off contact, and additional slots for optional cards			
	User interface	LCD and function keys (parameters: voltage, frequency, load percentage, battery voltage, output voltage, estimated uptime, UPS temperature).			
	Optional accessories	Cards: SNMP, RS485 ModBus, dry relay contacts			
	Compatible software platforms	Microsoft Windows, Linux, Mac OS, VMware			
REGULATIONS	Standards	EN 50171, IEC EN 62040-1, IEC EN 62040-2, IEC EN 62040-3			
	Marking	CE, UKCA			

\* Subject to conditions \*\* To be verified according to the battery parameters



## CPSS THREE-PHASE TECHNICAL DATA SHEET

MODEL		CPSS 3P 10 KVA	CPSS 3P 20 KVA	CPSS 3P 30 KVA	CPSS 3P 40 KVA
POWER	kVA	10	20	30	40
	kW	9	17	27	33
INPUT	Rated voltage	400 V three-phase with neutral			
	Voltage tolerance	±20%			
	Rated frequency	40 – 70 Hz			
	Power factor	≥0.99			
	Current distortion (THDi)	≤ 4% at full load	≤ 3% at full load		
OUTPUT	Rated voltage	380/400/415 V three-phase+neutral			
	Voltage stability	±1% (static load)			
	Frequency	50/60 Hz			
	Frequency stability	±0.01% (free running)			
	Power factor	0.9	0.85	0.9	0.825
	Crest factor	3:1			
	Voltage distortion	≤2% with linear load, ≤5% with distorting load			
	Permissible overload	120% permanent load, 125% for 10 minutes, 150% for 1 minute			
EFFICIENCY	VFI mode	Up to 95%			
	ECO mode	Up to 98%			
	In battery	Up to 94%			
GENERAL	Parallel connection	Up to 6 units			
	Dimensions (WxDxH) mm	260x850x890 (including wheels)			
	Weight (kg)	74	76	85	88
	Alarms	Audible and visual alarm alerts for: incorrect battery polarity, short circuit, power failure, low battery, bypass transfer, and UPS fault, etc.			
	Protection	Battery polarity, short circuit, overload, overheating, deep discharge, overcharging.			
	Operating mode	Multimode: VFI, ECO, Emergency (SE), Mixed mode (SA and SE with separate outputs)			
	Cold start from the battery without mains power	Included			
	Protection class	IP 20			
	BATTERY	Number per string (12V)	40 pcs		
Common battery for parallel configuration		Supported			
Internal battery (optional)		Up to blocks 40 12 V 7/9 Ah batteries		N.A.	
Max. charging current*		12.9 A	14.5 A	24.7 A	28 A
Cold start from the battery without mains power		Included			
BYPASS	Rated voltage	380/400/415 V three-phase+neutral			
	Voltage tolerance	Basic window ±10% (programmable ±5% – ±15%)			
		Critical window ±25% (programmable ±16% – ±30%)			
	Frequency	50/60 Hz			
	Frequency tolerance	±1 Hz / ±3 Hz (selectable)			
Protection	Fuses				
ENVIRONMENTAL PARAMETERS	Operating temperature**	0 – 40°C			
	Altitude (a.s.l.)	<1000 m with no power derating, >1000 m with 1% derating for every 100 m.			
	Relative humidity	0 – 95% (without condensing)			
	Audible noise at 1 m.	<52dB		<55dB	
CONNECTIVITY	User interface	4.3" colour LCD touch screen display with removable SD card			
	Built-in communication ports	USB, RS232, EPO, 3 out dry relay contacts (programmable) and two additional slots for optional cards			
	Optional accessories	Cards: SNMP, RS485, ModBus, 6 in/6 out dry relay contacts, touch panel for remote monitoring, Mixed mode kit			
REGULATIONS	Standards	EN50171, IEC EN 62040-1, IEC EN 62040-2, IEC EN62040-3			
	Marking	CE, UKCA			

\* Subject to conditions \*\* To be verified according to the battery parameters

## CPSS

### Accessories

#### CPSS ZEN single-phase

**COMMUNICATION CARDS** for sending the CPSS status to a control computer

<b>DCE-C:</b> Programmable card with dry contacts with dry contacts with client software included.
<b>SNMP ABL:</b> Network card CY504B for sending data, controlling CPSS and receiving alarms via email with SNMP protocol. Client software is included.
<b>SNMP GEN P:</b> 3-port Genex card (CS141SC) for controlling CPSS, and receiving alarms via SMS or/and email. Includes network interface for sending data with SNMP protocol, port for environmental monitoring sensor connection or RS232 adapter (ModBus or GPRS/GSM modem), and port connecting alarm contacts. One RCCMD client software is included.
<b>SNMP GEN:</b> Network card (CS141BSC) for CPSS control, sending data, and reception of alarms via email, via SNMP protocol. One RCCMD client software license is included.
<b>RS485 CARD:</b> Internal for data exchange via the R485 protocol.

**EXTERNAL BYPASS** to ensure power continuity to the load during maintenance

<b>MTBS-60:</b> 60A bypass panel.
<b>MTBS-120:</b> 120A bypass panel.
<b>MTBS-200:</b> 200A bypass panel.
<b>Rack-BP_PDU-50:</b> External manual bypass with additional 50A sockets (4 x 16A IEC and 8 x 10A IEC) or powered by CPSS.

**ISOLATION TRANSFORMERS** for protection against electric shocks and ensure power availability to sensitive equipment

<b>TRAFO06:</b> Transformer for 6 kVA.
<b>TRAFO10:</b> Transformer for 10 kVA.

#### CPSS ZEN three-phase

**COMMUNICATION CARDS** for sending the CPSS status to a control computer

<b>SNMP GEN:</b> Genex network card (CS141BSC) for sending data with SNMP protocol for UPS control and reception of alarms via email. One RCCMD client software license included.
<b>TS-KR-SNMP-1:</b> Network card for sending data with SMNP protocol for controlling the UPS and reception of alarms via sms or/and email and, with port to measure temperature and humidity. Client software included.
<b>TS-KR-EMD:</b> Environmental monitoring sensor for SNMP card with temperature and humidity monitoring.
<b>TS-KR-485:</b> Card for data exchange via the RS-485 protocol.
<b>TS-KR-DEC:</b> 6 in 6 out programmable relay card with dry contacts for sending data to PLC, SCADA or AS400.

**ISOLATION TRANSFORMERS** for protection against electric shocks and ensure power availability to sensitive equipment

<b>TRAFO10:</b> Transformer for 10 kVA.
<b>TRAFO20:</b> Transformer for 20 kVA.
<b>TRAFO30:</b> Transformer for 30 kVA.
<b>TRAFO40:</b> Transformer for 40 kVA.

**PARALLEL KIT** to share the load among more than one CPSS to increase capacity and redundancy

<b>PARRIT KR:</b> Parallel kit composed of card and 1.5 m cable.
<b>PARCAB30:</b> 3 m parallel connection cable.
<b>PARCAB80:</b> 8 m parallel connection cable.

**MIXED MODE KIT:** to have SA and SE with separate outputs MIXED.

<b>OP4ZEN:</b> wall-mounted kit with contactor for mixed mode 40 kW (150A).
---

## Operating mode

### Online mode (VFI)

The load is always powered (SA) by the inverter.

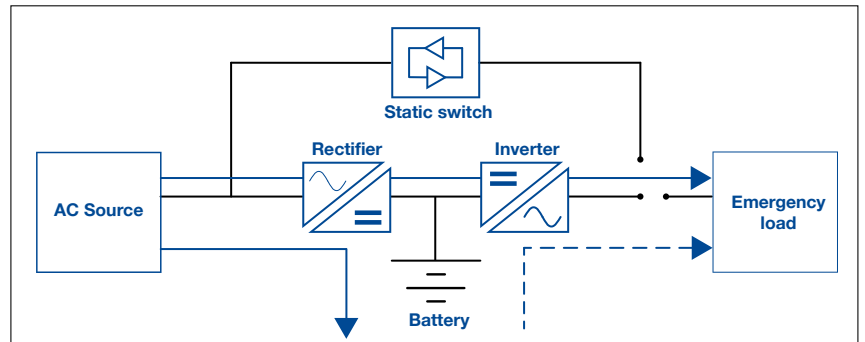

### ECO mode

The load is powered by the bypass during normal operation and by the inverter when there is no mains or it is out of tolerance.

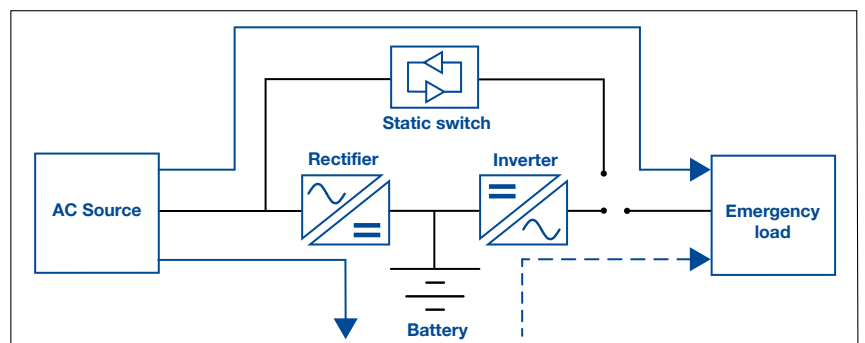

### Emergency mode (SE)

The load is only powered by the inverter when there is no mains or it is out of tolerance.

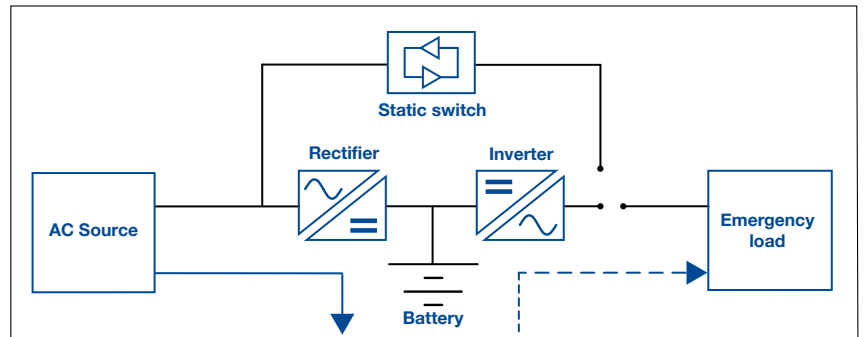

### Mixed mode

One load is always powered by the inverter, while the other load is only powered by the inverter when there is no mains or it is out of tolerance (SA and SE with separate outputs).

The three-phase version required the optional Mixed mode kit.

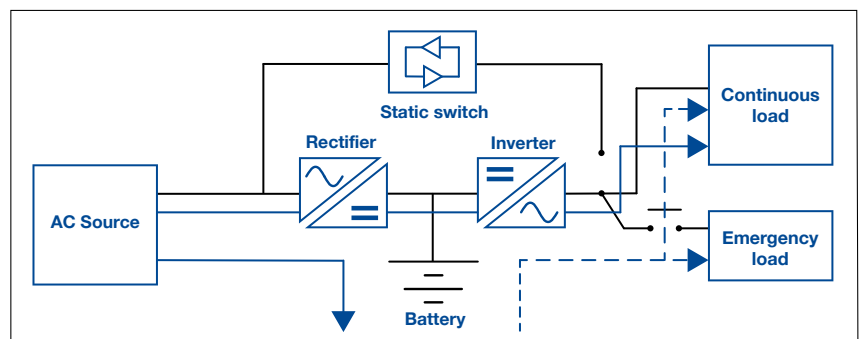

# POWER QUALITY DEVICE

Innovative solutions  
for maximum protection,  
control and unparalleled  
power quality



**ESP**  
Active filters

**STS**



**ATS**  
Active transfer switches



**BMS**  
Battery monitoring system

## ESP

- Enersine active wall-mount filters offer the most economical and effective solution, while the scalability of the modular ones protects your investment over time.
- The power modules of the modular version are easy to install and are hot swappable: they can be replaced while the filter is operating.
- Versatile thanks to the modularity, high nominal current and possibility of parallel connection up to 400 A for the wall version, and up to 2400 A for the modular version.
- Enersine is available in two versions, 4 or 6 modules for 60 A, 80 A or 100 A, which can also be used in a mixed configuration within the same system.
- Maximum performance with 3-level DSP technology.
- Their compact, high-power-density design optimises space.
- Multi-purpose: one model covers all three-phase systems (3-wire or 4-wire).
- Correction of all harmonics up to the 51st (up to the 25th for 30 A) with a response time of less than 1 ms.
- No overload effect.
- Selective mode to select the harmonics to be corrected.
- Phase balancing of three-phase loads.
- Open loop or closed loop installation.
- A single control module manages up to 8 power modules.
- All parameters are under control via the 7" colour (2.7" LCD for 30 A model) touch screen display that shows: voltage and current waveforms, frequency spectrum, parameters and events.
- Events and parameters can be downloaded to a removable SD card.
- Advanced communication: dry contacts (3 in and 1 out), USB, RS485 Modbus, RJ45 Ethernet, programmable email alarm.

### User-friendly user interface

The 7" colour touch screen display can be used to set all parameters, read the event log file and download data to a removable SD card (for 60 A, 80 A, 100 A wall-mounting model and all modular models).

It can also show the voltage and current waveforms, before and after enabling the Enersine, along with a frequency spectrum bar graph.



### Open/closed loop control

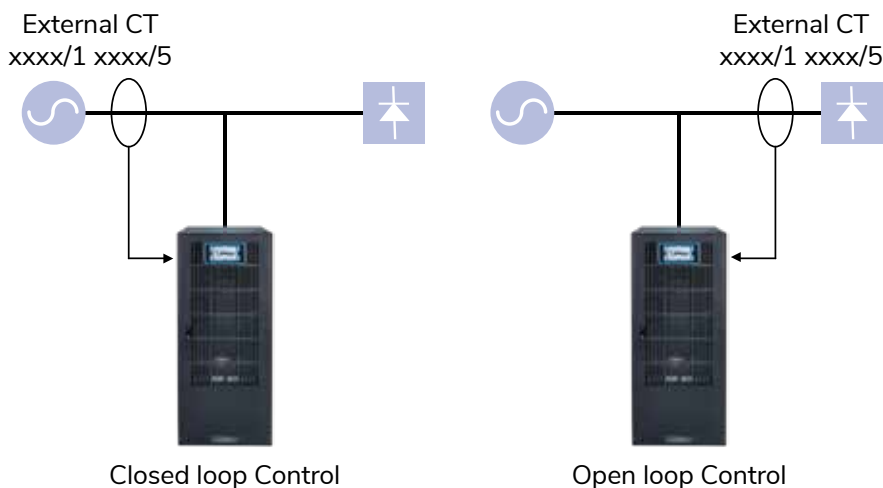

Ablerex Enersine active filters can correct any type of harmonic contamination to protect the system from faults (e.g. burnt-out transformers, damaged capacitors, etc.), while also improving the power factor.

## ESP wall-mount 30-100 A



## ESP modular 400-600 A



### Applications

- Broadcasting
- Shopping centres
- Energy suppliers
- Transport infrastructure and control rooms
- Oil&Gas
- Healthcare sector



Generator

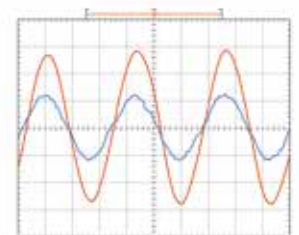
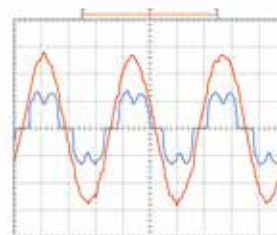

Power Utility



Non-Linear Load

### Harmonic and PF correction that can be verified on the display

Alerex Enersine not only actively corrects harmonic currents up to the 51st order, but also improves the inductive or capacitive power factor with a response time of less than 1 ms. The benefits can be seen easily on the display.

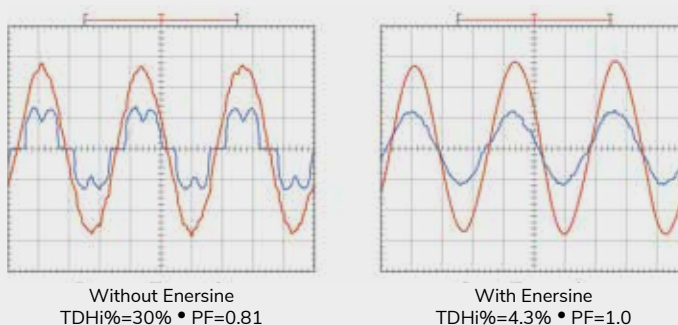

### ESP MONOLITHIC TECHNICAL DATA SHEET

MODEL		ESP 30	ESP 60	ESP 80	ESP 100
SIZE (A)		30	60	80	100
ELECTRICAL SPECIFICATIONS	Rated voltage	400 V +15%, -20%; 480V +10%, -20%			
	Phases	Three-phase			
	Frequency	50/60 ±3 Hz			
	Harmonic correction	From the 2nd to the 51st *			
	Power factor correction	Capacitive and inductive (selectable)			
	Load balancing	Between two phases and between phase and neutral			
	Response time	25 µs			
ENVIRONMENTAL PARAMETERS	Operating temperature	-10°C to +40°C with no derating **			
	Relative humidity	<95%			
	Altitude (a.s.l.)	<1000 m with no derating, >1000 m with 1% derating for every 100 m			
	Audible noise at 1 m.	<55 dBA	<63 dBA		
GENERAL	Dimensions (WxDxH) mm	348x164x598	500x286x775		
	Weight (kg)	16	51	58	60
	Protection class	IP30/IP31			
	Connections	4-wire/3-wire			
	Installation	Wall mounting			
	Type	Monolithic			
	Parallel connection up to (A)	120	240	320	400
	Max. parallel modules	4			
	TA configuration	Source side TA: closed loop control - load side TA: open loop control			
CONNECTIVITY	Built-in communication ports	USB, RS-485 ModBus RTU, EPO and Dry contact board (1 input – 3 output)	USB, RS-485 ModBus RTU, EPO, Ethernet and Dry contact board (1 input – 3 out-put)		
	User interface	Colour 2,7" LCD screen display	Colour 7" LCD touch screen display		
	Software	Data monitoring and storage software			
REGULATIONS	Standards	EN61000-6-4, EN55011, CISPR 11, IEC 61000-3-12, IEC 61000-3-11			
		IEC 61000-6-2, IEC 61000-4-2, IEC 61000-4-3, IEC 61000-4-4			
		IEC 61000-4-5, IEC 61000-4-6, IEC 62477-1, EN 61000-4-8, EN61000-4-34			
Marking	CE, UKCA				

\* Up to the 25th for 30 A \*\* Enersine 30 model: -10°C to +25°C without derating, above +25°C automatic derating to 20A



## ESP MODULAR TECHNICAL DATA SHEET

MODEL		ESP 400	ESP 600
SIZE (A)		400	600
POWER MODULE (A)		60-80-100	
ELECTRICAL SPECIFICATIONS	Rated voltage	400 V +15%, -20%; 480V +10%, -20%	
	Phases	Three-phase	
	Frequency	50/60 ±3 Hz	
	Harmonic correction	From the 2nd to the 51st	
	Power factor correction	Capacitive and inductive (selectable)	
	Load balancing	Between two phases and between phase and neutral	
	Response time	25 µs	
ENVIRONMENTAL PARAMETERS	Operating temperature	-10°C to +40°C with no derating	
	Relative humidity	<95%	
	Altitude (a.s.l.)	<1000 m with no derating, >1000 m with 1% derating for every 100 m	
	Audible noise at 1 m.	<63 dBA	
GENERAL	Dimensions (WxDxH) mm	600x900x1500	600x900x1950
	Weight (kg)*	150	196
	Protection class	IP21	
	Connections	4-wire/3-wire	
	Installation	Floor standing	
	Type	Modular	
	Parallel connection up to (A)	2400	
	Max. no. of modules per system (60/80/100 A in a mixed configuration)	Up to 4	Up to 6
	Max. parallel systems	6	4
	TA configuration	Source side TA: closed loop control - load side TA: open loop control	
CONNECTIVITY	Built-in communication ports	USB, RS485, Modbus RTU, EPO Ethernet port and dry relay contacts (1 in/3 out)	
	User interface	7" colour LCD touch screen display	
	Software	Data monitoring and storage software	
REGULATIONS	Standards	EN61000-3-4, IEEE 519-1992, EN60146, EN50178; UL508, EN61000-6-4, EN55011, CISPR 11, IEC 61000-3-12, IEC 61000-3-11, IEC 61000-6-2, IEC 61000-4-2, IEC 61000-4-3, IEC 61000-4-4, IEC 62477-1, IEC 61000-4-5, IEC 61000-4-6, EN 61000-4-8, EN61000-4-34	
	Marking	CE, UKCA	

\* Weight without the control module and power modules

## STS

- Provides redundant power to single-input equipment by managing two separate, independent power sources.
- Maximum automatic transfer speed between two sources:  $\leq 5$  ms for the 63 A versions,  $\leq 4$  ms for the 100 A to 1250 A versions.
- Maximum protection: it automatically inhibits the transfer in the event of a downstream short circuit, preventing damage to both sources.
- Total source independence and internal redundancy on all components including bypass, power supplies, cooling systems etc. ensures maximum continuity to the connected loads.
- Direct front access to all components and separate dual manual bypass guarantee easy and safe maintenance.
- Continuous input voltage and frequency monitoring to allow safe switching without source cross-overs.
- Real-time SCR status detection and backfeed protection for maximum upstream system safety.
- Circuit breakers for improved protection in all conditions.
- RS232, RS485 ModBus ports, dry contacts and slots for optional communication card.

### Key options

- Additional dry contacts card.
- Operation without neutral.
- Isolation transformer.
- Top cable entry.
- 4-pole configuration with switched neutral.

## STS Central static transfer systems for maximum availability in critical applications

High performance: maximum transfer speed, high power management and high overload capacity.



### Applications

- Data centres
- Telecommunications and broadcasting equipment
- Industrial applications

## STS TECHNICAL DATA SHEET

MODEL		STS 100A-3p	STS 250A-3p	STS 400A-3p	STS 630A-3p	STS 800A-3p	STS 1000A-3p	STS 1250A-3p
SIZE (A)		100	250	400	630	800	1000	1250
INPUT	Terminal block	4-wire terminals						
	Rated voltage	208/380/400/415/440/480 Vac three-phase with neutral						
	Voltage tolerance	±10% (up to ±20% on request)						
	Frequency	50/60 Hz, ±2 Hz (up to ±4 Hz on request)						
	Source harmonic voltage content	Unlimited (>20%THD, switching time ≤10 ms)						
	Switching phase angle	5° to 30°						
OUTPUT	Terminal block	4-wire terminals						
	Frequency	50/60 Hz						
	Switching time	≤4 ms						
	Switching type	Break before make, switching inhibited on fault						
	Power factor	1 to 0.3						
	Maximum crest factor	3:1						
	Load current distortion	Unlimited						
	Permissible overload	125% for 30 min, 150% for 10 min, 200% for 30s, 2000% for 1 cycle, 4000% for 1/2 cycle						
EFFICIENCY	(AC/AC)	>99%						
GENERAL	Dimensions (WxDxH) mm	820x835x1475			1220x860x1900			2000x1000 x2100
	Weight (kg)	265	290	305	615	660	1000	1450
	Protection	IP20						
	Installation layout	Wall mounting, back to back, and side by side						
	Access	Front access, top and bottom cable entry						
ENVIRONMENTAL PARAMETERS	Operating temperature	0°C to +40°C						
	Altitude (a.s.l.)	<1000 m with no power derating, >1000 m with 0.5% derating for every 100 m						
	Audible noise at 1 m	≤62 dBA						
CONNECTIVITY	User interface	LCD graphic display, LED synoptics and function keys						
	Built-in communication ports	Relay contact card, RS232, RS485, ModBus-RTU adapter						
	Optional accessories	Additional relay contact card						
REGULATIONS	Standards	IEC EN 62310-1, IEC EN 62310-2, IEC EN 62310-3, IEC EN 62947-3						
	Marking	CE, UKCA						

# ATS

- Redundant power to single-input equipment by managing two separate, independent power sources.
- High automatic transfer speed between two sources (8 - 12 ms).
- The LCD display makes it easy to control.
- Takes up minimal space: 1U for 16 A and 2U for 32 A.
- EPO for greater safety.
- The ITS version with manual bypass and hot-swappable ATS guarantees 100% power continuity.
- Output sockets:
  - 16 A version: 8 x IEC C13 and 1 x IEC C19
  - 32 A version: 12 x IEC C13 and 2 x IEC C19 + terminals.
- USB and RS232 ports, relay card with dry contacts and slots for optional communication cards.

### Key options

- SNMP/web and RS485 card for remote management

## ATS Automatic transfer systems

These guarantee redundant power to rack equipments with a single power supply.



### Applications

- Server rooms
- Data centres
- Networking equipment
- Video surveillance and security equipment

## ATS TECHNICAL DATA SHEET

MODEL		ATS-16A-1P	ATS-32A-1P	ITS-32A-1P
SIZE (A)		16	32	32
INPUT	Rated voltage	200/208/220/230/240 Vac (±5%/10%/15%/20%)		200/208/220/230/240 Vac (±5%/10%/15%/20%)
	Frequency	50/60 Hz (±5%/10%/15%/20%)		
	Input sockets	2 x IEC-C20	2 x 32 A terminal blocks	2 x 32 A terminal blocks
OUTPUT	Rated voltage	200/208/220/230/240 Vac		200/208/220/230/240 Vac
	Maximum output current	16	32	32
	Transfer time	8–12 ms		
	Output sockets	8 x IEC-C13 1 x IEC-C19	12 x IEC C13, 2 x IEC C19 1 x 32 A terminal blocks	12 x IEC C13, 2 x IEC C19
CONNECTIVITY	Built-in communication ports	RS232, USB, EPO, relay card with dry contacts (5 out)		
	User interface	LED (source A and/or B, fault status) LCD (parameters: alarms, faults)		
	Optional accessories	RS485, SNMP/Web cards		
GENERAL	Dimensions (WxDxH) mm	440x275x44	440x275x88	440x346x88
	Weight (kg)	4	6	8
	Protection	Downstream short circuit		
ENVIRONMENTAL PARAMETERS	Operating temperature	-5°C to + 40°C (0%–90% non-condensing)		
REGULATIONS	Standards	IEC EN 62368-1, IEC EN 62310-2		
	Marking	CE, UKCA		

ERMES 16A

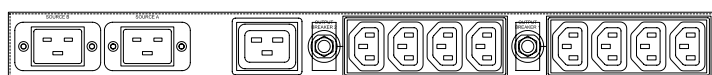

ERMES 32A

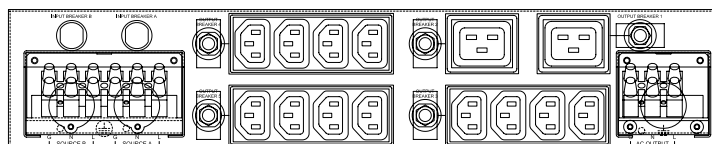

ERMES 32A BP

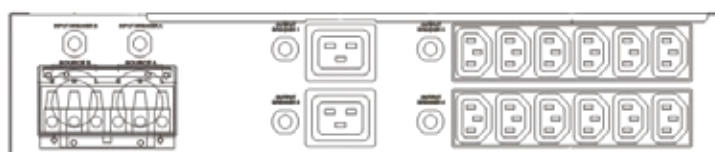

## BMS

- Total flexibility with 2.4 GHz wireless communication technology that requires no preventative design and allows rack and cabinet configurations to be changed at any time.
- Everything easily under control: the most important parameters of each battery block are measured, including impedance, voltage, current and temperature.
- Very simple and fast installation ensures good savings.
- Each block has an equalization function to prevent spikes and maximise battery life and performance.
- Each ENERBATT system can monitor and protect up to 750 blocks.
- Automatically disables the measurement instrument if the end-of-discharge voltage is reached in order to safeguard the batteries.
- The measurement instruments are re-enabled automatically when the charging current is restored.
- Update frequency of 1 Hz ensures accurate measurements.
- Simultaneous management of batteries of different capacities and types (e.g. VRLA, AGM, NiCd, OPTS, OPZV, etc.) and mixed voltage configurations (e.g. 48 V and 240 V battery systems).
- Colour touch screen display to clearly see configurations and parameters, including diagrams and voltage trend plots.
- Programmable alarm level.
- Alarm alerts via email and dry contact.
- Removable SD card for event storage.
- RS485 port for communication between the receiver and control panel for monitoring large plants.
- Ethernet port and additional RS485 port for remote monitoring.

### Key options

- Temperature sensor for each block.
- Sensor kit for use with Ni-Cd batteries.
- Additional antenna for each battery string meter (BMS-SMK) to extend the wireless range.
- Dedicated software for remote monitoring and data storage.

### Battery voltage equalizer

Continually equalizes the end-of-charge voltage of the batteries to the optimal level in order to prevent overcharging and ensure the best performance and durability. With the equalization function active, the voltage of each battery block is continually kept at the ideal value.

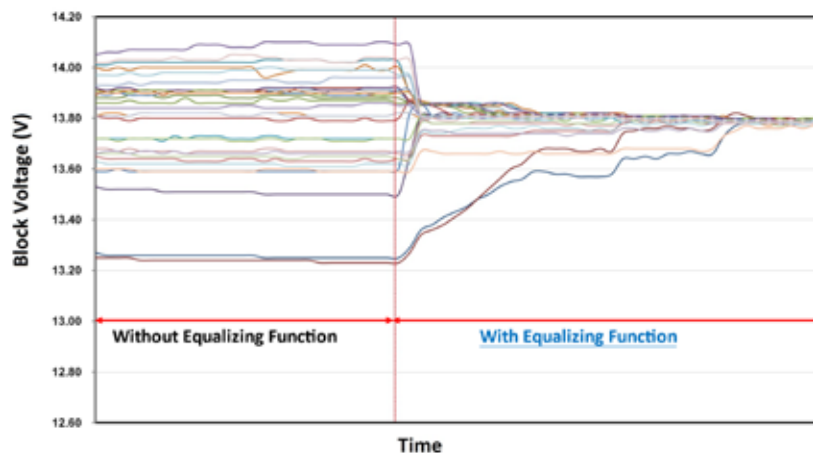



## **BMS** **Wireless battery analysis,** **monitoring and protection** **system**

The voltage equalization function between the individual blocks guarantee the lowest installation and operating cost, maximum performance and battery system life.

### **Applications**

- Server rooms
- Data centres
- Telecommunications equipment
- Industrial automation systems
- TV broadcast equipment
- Video surveillance equipment
- Electrical panels and cabinets
- Electromedical equipment
- Energy storage systems

## BMS

### Wireless Battery Monitoring System

- **Easy**  
The wireless design simplifies installation and makes maintenance cost effective.
- **Flexible**  
No pre-design is needed, it can be adapted easily to any further configuration changes.
- **Intelligent**  
Real-time monitoring via graphic LCD touch screen or web, programmable email alarms.  
Guarantees savings in investment and operating expenses (CAPEX and OPEX).
- **Powerful**  
One collector for up to 750 batteries of any type and 63 RF receivers. Battery protection is always active thanks to the equalisation functions.

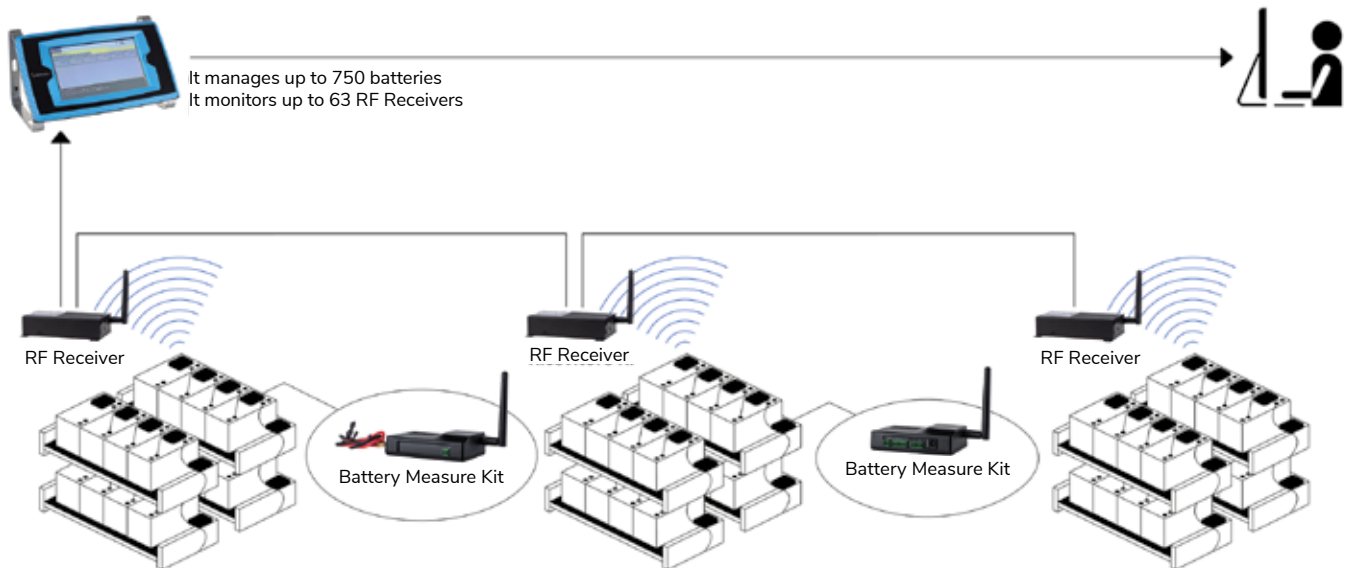



## BMS TECHNICAL DATA SHEET

MODEL		SPECIFICATIONS				
BMS-DC-LCDII (Central Unit)	User interface	7" colour LCD touch screen display				
	Supply voltage	12 Vdc				
	Power consumption	≤ 9 W				
	Communication ports	Ethernet, 2 RS485 Modbus RTU, dry relay contacts (1 in/3 out)				
	RF receiver monitoring	Up to 63 RF receivers				
	Wireless devices that can be connected	Up to 750				
	Storage capacity	SD memory card up to 16 gigabytes				
	Dimensions (WxDxH) mm	260x57x150				
	Weight (kg)	0.85				
BMS-RFR (RF receivers)	Supply voltage	12 Vdc				
	Power consumption	≤ 3 W				
	Operating frequency	RF 2.4 GHz (wireless)*				
	Wireless devices that can be connected	Up to 256				
	Dimensions (WxDxH) mm	129x70x35.5				
	Weight	0.4				
BMS-BMK (Battery meter)	Voltage	1.2V (Ni-Cd)	2 V	6 V	12 V	
	Measurement range	0.95–2.00 V	1.48–4.00V	4.2–8.0V	8.5–16.0V	
	Tolerance	±5 mV			±10 mV	
	Impedance measurement accuracy	2 μΩ		10 μΩ	>65 Ah 15 μΩ	<65 Ah 25 μΩ
	Measurable temperature**	0–100°C ±1°C				
	Power consumption	≤ 0.5 W				
	Input impedance	≥ 1 mΩ				
	Dimensions (WxDxH) mm	100x70x27				
	Weight (kg)	0.1				
BMS-SMK (Battery Monitoring System) SMK (String meter)	Measurement range	0–120 V		120–750 V		
	Tolerance	±0.2%				
	Measurable temperature	0–100°C ±1°C				
	Measured current range***	0–3000 A				
	Supply voltage	12 Vdc				
	Power consumption	≤1.5 W				
	Input impedance	≥1 mΩ				
	Dimensions (WxDxH) mm	100x70x27				
	Weight (kg)	0.09				

\* The maximum transmission distance is estimated to be 50 m if there are no obstacles. A distance of less than 20 m is recommended for optimal performance.

\*\* The optional temperature sensor (TES) is required in order to measure the temperature.

\*\*\* The optional Hall-effect current transformer (HCT) is required in order to measure the battery current.







Rev.2025/01 - Our commitment to continuous innovation means that catalogue data may be subject to change without notice

### **AblereX Electronics Italy srl**

Viale Milanofiori · Strada 6 · Palazzo N1  
20089 Rozzano (MI)  
info@ablereX.eu · Tel. +39 02 36696420  
www.ablereX.eu

### **AblereX Electronics Ltd**

19 The Circle Queen Elizabeth Street,  
London, Greater London SE1 2JE - UK  
info@ablereX.uk · Ph. +44 (0) 7920 058834  
www.ablereX.uk